

Low-cost, High-quality Digital Thermometer with Built-in Microcomputer

- Compact (96 W x 48 H x 66 D) DIN-size body
- Requires only 3.5 mm of mounting thickness
- Highly visible 14.2-mm LED display
- Multi-temperature range incorporated
- Upper or lower limit selectable (models with alarm output)
- Optional: water-resistant, IP51 construction



Ordering Information

Temperature Range

Item		Thermocouple				Platinum resistance thermometer		
Input		K (CA)		J/L (IC)		Pt100/JPt100		
Temperature range		0° to 400°C	0° to 999°C	0° to 300°C	0° to 500°C	0° to 99.9°C	0° to 400°C	-50° to 50°C
		0° to 400°F	0° to 999°F	0° to 400°F	0° to 999°F	0° to 99.9°F	0° to 800°F	0° to 200°F
Range selection		4-range selectable				3-range selectable		
Model	Display only	K3TL-TA11				K3TL-TB11		
	With alarm output	K3TL-TA11-C				K3TL-TB11-C		

Note: The °C or °F display can be selected. For details, refer to *Measuring Ranges*.

Model Number Legend

K3TL - -
 1 **2** **3** **4** **5**

1, 2. Input Sensor Code

TA: Thermocouple (K, J)

TB: Platinum resistance thermometer (Pt)

3. Series No.

1: Current series

4. Supply Voltage

1: 100 to 240 VAC

8: 24 VAC (24-VAC type is available by request.)

5. Output

None: Without relay output

C: With relay output

■ ACCESSORIES (ORDER SEPARATELY)

Description	Appearance	Part number
Water-resistant Soft Front Cover		K32-L49SC
Terminal Cover		K32-L49TC

Specifications

■ RATINGS

Supply voltage		100 to 240 VAC (50/60 Hz)
Operating voltage range		-15% to +10% of supply voltage
Power consumption		6.6 VA (at max. load) (see note)
Insulation resistance		10 M Ω min. (at 500 VDC) between external terminal and case
Dielectric strength		2,000 VAC min. for 1 min between input terminal and power supply 2,000 VAC min. for 1 min between external terminal and case
Noise immunity		\pm 1,500 V on power supply terminals in normal or common mode
Vibration resistance	Malfunction	10 to 55 Hz, 0.5-mm single amplitude for 10 min each in X, Y, and Z directions
	Destruction	10 to 55 Hz, 0.75-mm single amplitude for 2 hrs each in X, Y, and Z directions
Shock resistance	Malfunction	100 m/s ² (approx. 10G) for 3 times each in 6 directions
	Destruction	300 m/s ² (approx. 30G) for 3 times each in 6 directions
Ambient temperature	Operating	-10° to 55°C; 14° to 131°F (with no icing)
	Storage	-20° to 65°C; -4° to 149°F (with no icing)
Ambient humidity	Operating	35% to 85% (with no condensation)
Ambient atmosphere		Must be free of corrosive gas
Approvals	UL	File No. E41515
	CSA	File No. LR67027

Note: An inrush current of approximately 1.0 A will flow at the moment power is turned on and continue for approximately 5 ms.

■ OUTPUT RATINGS

Item	Resistive load (cos ϕ = 1)	Inductive load (cos ϕ = 0.4, L/R = 7 ms)
Rated load	5 A at 250 VAC; 5 A at 30 VDC	1.5 A at 250 VAC; 1.5 A at 30 VDC
Rated carry current	5 A max. (at COM terminal)	
Max. contact voltage	380 VAC, 125 VDC	
Max. contact current	5 A max. (at COM terminal)	
Max. switching capacity	1,250 VA, 150W	375 VA, 80 W
Min. permissible load	10 mA at 5 VDC	

■ CHARACTERISTICS

Measuring accuracy		\pm 0.5% FS \pm 1 digit (see note 1)
Input	Thermocouple	K (CA), J/L (IC)
	Platinum resistance thermometer	JPt100/Pt100
Sampling period		2 times/s
Display refresh period		2 s (average of 4 sampling data)
Display		7-segment LED
Display scale		°C or °F display selectable
Input shift		-99° to 99°C/°F or -9.9° to 9.9°C/°F (see note 2)
Alarm output function		Output configuration: Relay contact (SPDT) Upper or lower range selectable with DIP switch
Enclosure ratings	Front panel	IEC IP51 (see note 3)
	Case	IEC IP20
	Terminals	IEC IP00

Note: 1. The measuring accuracy is at an ambient temperature of 25 \pm 5°C.

2. This applies only to a platinum resistance thermometer with an input range of 0° to 99.9°C/°F.

3. IP51 is maintained when the water-resistant soft cover and bracket are used. IP50 will, however, be maintained without these water-resistant accessories.

MEASURING RANGES

Input		Measuring ranges		Hysteresis (see note)
Thermocouple	K	0° to 400°C	0° to 400°F	1° C/°F
		0° to 999°C	0° to 999°F	1° C/°F
	J/L	0° to 300°C	0° to 400°F	1° C/°F
		0° to 500°C	0° to 999°F	1° C/°F
Platinum resistance thermometer		0.0° to 99.9°C	0.0° to 99.9°F	0.1°C/°F
		0° to 400°C	0° to 800°F	1° C/°F
		-50° to 50°C	0° to 200°F	1° C/°F

Note: Hysteresis of alarm output set value (fixed value for each range)

Nomenclature

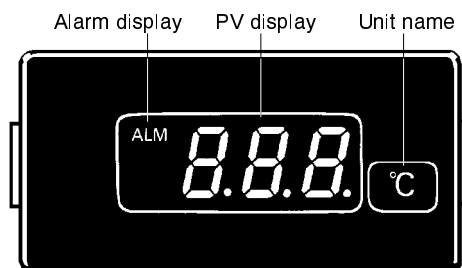

Operation

The lower part of the front panel cover has two grooves. Hook the grooves with a flat-blade screwdriver to remove the cover before operating the K3TL.

Without cover

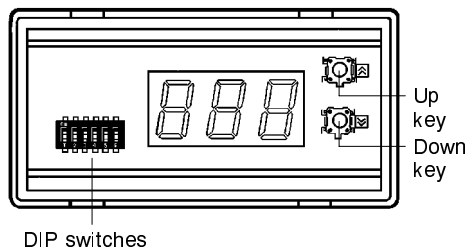

Note: After the front panel cover is removed to select the function or perform the necessary settings, do not touch components other than the dip switch or keys. Keep all metal objects off the K3TL, especially when power is turned on.

Item	Function
DIP switches	Used to select input range, display unit, alarm mode.
Up/Down Key	Used to select alarm set value and input compensation value.

■ DIP SWITCH SETTING

The DIP switch pins are all set to OFF before shipping. Refer to the following tables for setting the DIP switch.

Note: Be sure to turn off the power before changing the settings of the DIP switch other than pin 6.

Thermocouple Models (K3TL-TA)

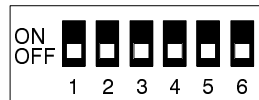

Function			Pin no.	Pin setting
Input range	K	0° to 400°C	1/2	OFF/OFF
		0° to 999°C		ON/OFF
	J/L	0° to 300°C		OFF/ON
		0° to 500°C		ON/ON
Specification (see note)	K, L (DIN)		3	ON
	K, J (JIS)			OFF
Scale	°F		4	ON
	°C			OFF
Alarm mode	Lower-limit (relay operates for values less than the set value)		5	ON
	Upper-limit (relay operates for values more than the set value)			OFF
Input compensation function	Input compensation value set mode		6	ON
	Usually set to OFF			OFF

Note: If a K-type sensor is used, you can set pin 3 to either ON or OFF.

Platinum Resistance Thermometer Models (K3TL-TB)

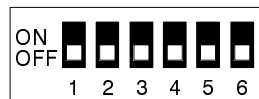

Function			Pin no.	Pin setting
Input range	0° to 99.9°C	0° to 99.9°F	1/2	OFF/OFF
	0° to 400°C	0° to 800°F		ON/OFF
	-50° to 50°C	0° to 200°F		OFF/ON
Specification	Pt100		3	ON
	JPt100 (JIS 1981)			OFF
Scale	°F		4	ON
	°C			OFF
Alarm mode	Lower-limit (relay operates for values less than the set value)		5	ON
	Upper-limit (relay operates for values more than the set value)			OFF
Input compensation function	Input compensation value set mode		6	ON
	Usually set to OFF			OFF

■ OPERATION TIMING OF ALARM OUTPUT

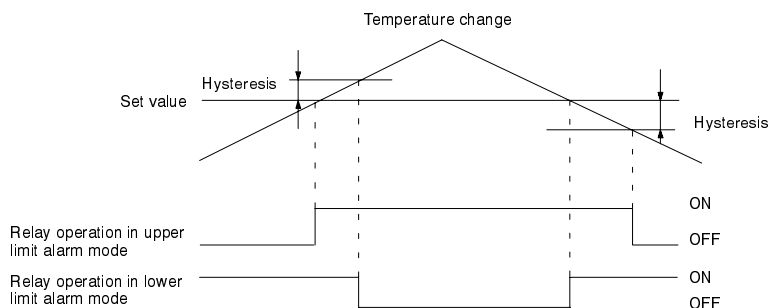

■ OPERATING PROCEDURES

Setting Alarm Value

Setting Range

-99 to 999 or -9.9 to 99.9 (°C/°F) regardless of the temperature range that you have selected.

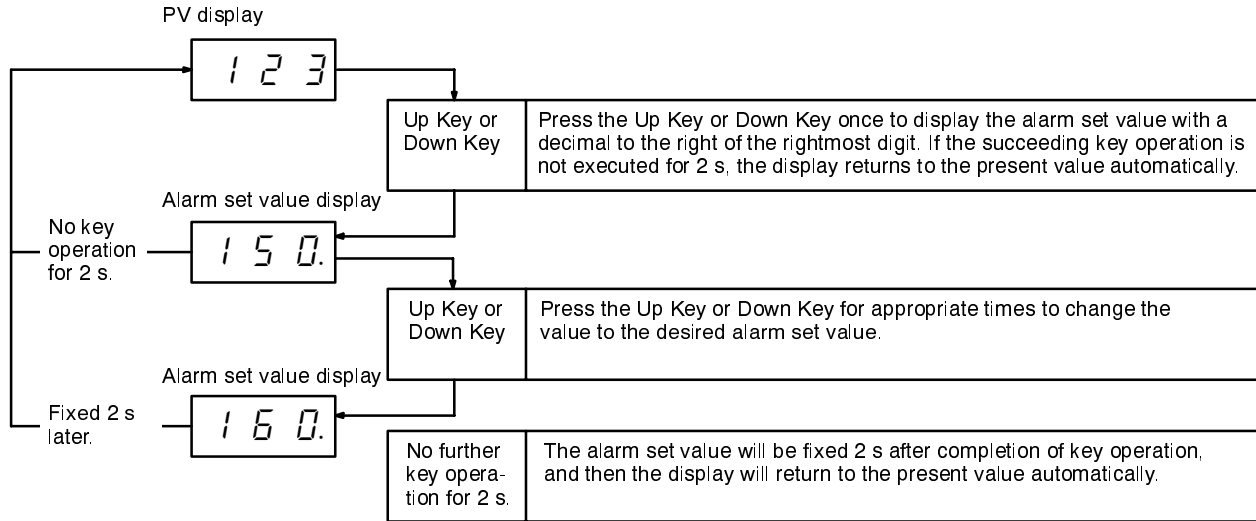

If you change the temperature range after you set the alarm set value, the new alarm set value will remain unchanged.

If you change the display unit, the alarm set value will not be converted from the °C to °F value or vice versa.

If you remove or add the decimal point from or to the display, the display value will change as follows:

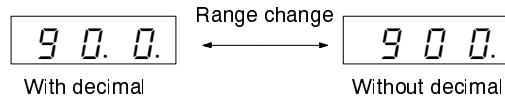

Setting Input Compensation (Shift)

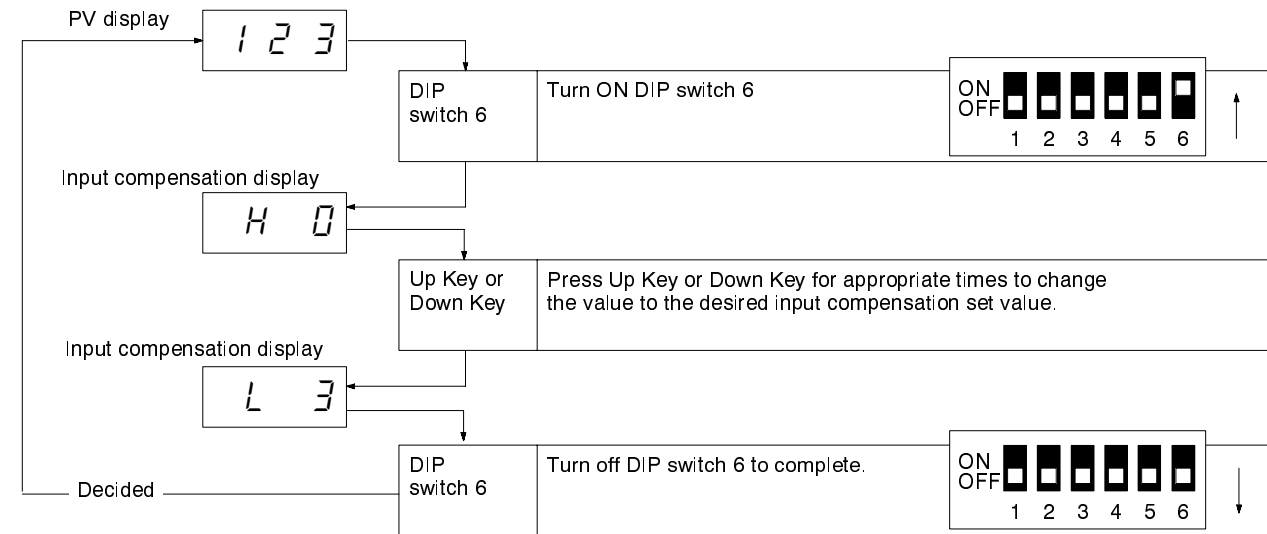

Possible Compensation Range for Each Temperature Range

Temperature range	Platinum resistance thermometer 0.0 to 99.9 (°C/°F)	Other ranges
Possible compensation range	-9.9 to 9.9 (°C/°F)	-99 to 99 (°C/°F)
Input compensation display	L9.9 L0 H9.9	L99 L0 H99

Example of Compensation

Input compensation value display	Sensor measurement temperature	Displayed temperature
H 0 (With no compensation)	100°C	100°C
H 9 (9°C compensation)	100°C	100°C
L 9 (-9°C compensation)	100°C	91°C

If you change the temperature range after you set the input compensation, the new input compensation will remain unchanged.

If you remove or add the decimal point from or to the display, the display value will change as follows:

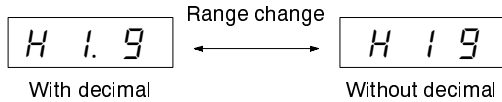
**■ DISPLAY WITH SENSOR ERROR****Thermocouple**

Condition		Message	Alarm output
Disconnected		FFF (flashes)	OFF

Note: The room temperature will be displayed if the input terminals are short-circuited.

Platinum Resistance Thermometers

Condition		Message	Alarm output
Disconnected		FFF (flashes)	OFF
	Breaks in 2 or 3 wires.	---	OFF
Short-circuited		---	OFF

Note: The Pt has a resistance of 100 Ω at a temperature of 0°C and approximately 140 Ω at a temperature of 100°C.

■ ERROR MESSAGES

The following table lists the error messages and the meaning of the error messages.

Message	Problem	Alarm output	Solution
FFF	The input temperature value is higher than the permissible measuring range.	The present setting will be put on hold.	Limit the input temperature value within the permissible range.
---	The input temperature value is lower than the permissible measuring range.	The present setting will be put on hold.	Limit the input temperature value within the permissible range.
FFF (flashes) --- (flashes)	A sensor error has occurred or the sensor temperature is far higher or lower than the permissible measuring range.	OFF	Remove the cause of the sensor error by referring to the error message.
E11 E33	A memory error (E11) or AD converter error (E33) has occurred.	OFF	Turn power on again. If the K3TL is still not reset, consult your OMRON representative.

Dimensions

Units: mm (inch)

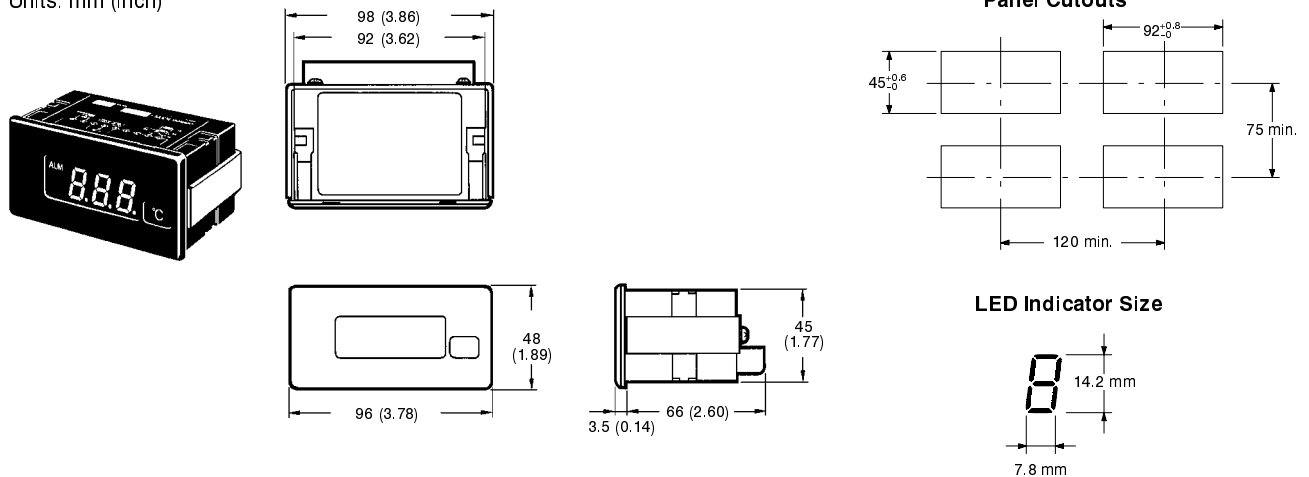

Installation

■ EXTERNAL CONNECTION

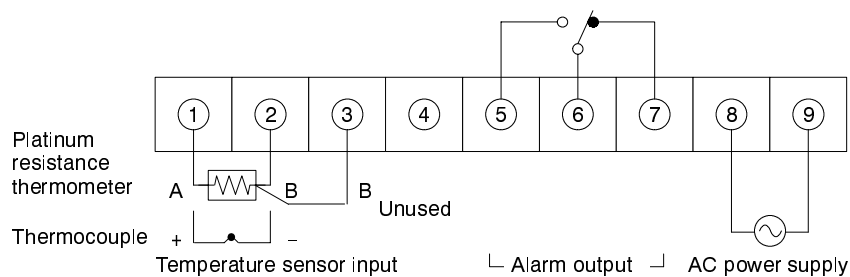

Note: Terminals 5, 6, and 7 are not used by models with no alarm output. (These terminals are open only for models incorporating the display function.)

Precautions

Installation

Location

- Never use the K3TL Digital Temperature Display in areas where corrosive gas (particularly sulfured or ammonia gas) is generated.
- Do not use the K3TL in a location subject to severe shock or vibration, excessive dust, or excessive moisture.
- Select an installation location where the K3TL can be used at an ambient operating temperature -10° to 55°C (14° to 131°F).
- Verify that panel thickness is 1 to 3.2 mm (0.04 to 0.13 in).
- Verify that the panel area and cut-out opening will allow the K3TL to be installed as perfectly horizontal as possible.

Installation Procedure

1. Insert the K3TL into the panel cut-out.
2. Secure the K3TL with the mounting bracket, fastening the mounting screws with a tightening torque of 5 kgf/cm (0.49 N/m). *Always* attach the mounting bracket before wiring.
3. Then, wire the terminals.

Attach the Unit Label

Select a unit label from the sheet provided, and attach it to the K3TL. (No product is shipped with the unit label attached.)



Removal Procedure

1. Loosen the screws and widen the bracket.
2. Always remove the wiring before removing the mounting bracket.

Selecting Functions or Settings

- Remove the front panel cover to select a function or perform the necessary settings.
- Keep all metal objects away from the K3TL, especially when power is turned on.
- Touch only the dip switch or keys. Do not touch other components.

Accessories (Order Separately)

Water-resistant Soft Front Cover

The K3TL will maintain IP51 water-resistant standards only after this water-resistant soft front cover and mounting bracket are properly attached to the K3TL. Attach these before installing the K3TL.

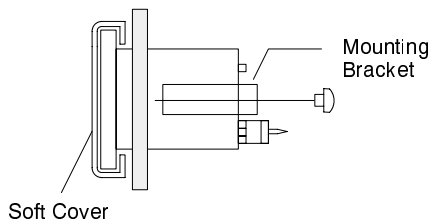

Note: Be sure to use the Water-resistant Soft Front Cover and mounting bracket together.

Calibration

Before you calibrate K3TL, remove the water-resistant soft front cover. (For the exact procedure, refer to the instruction sheet enclosed with the product.)

Noise Insulation

Power Supply

Although all possible counter-measures against noise have been taken, the K3TL Temperature Display cannot resist excess noise. If a power relay, magnetic switch, or high-frequency device is connected to the power supply line or if there is a possibility of a high-voltage spark or abnormal voltage generation due to lightning, connect a noise absorption circuit such as a line filter, noise-cut transformer, or varistor to the K3TL Temperature Display.

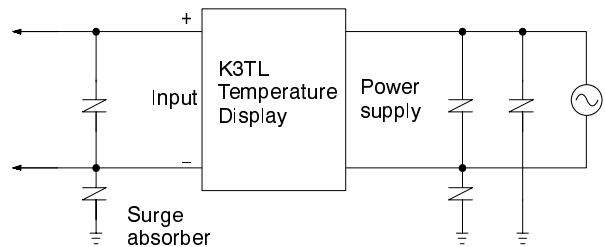
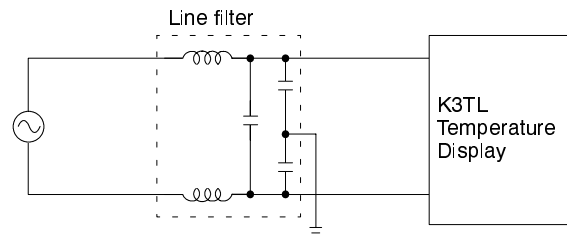

Induced Noise

If induced noise is a problem, shield the K3TL Temperature Display with a metal cover and ground the metal cover. To reduce induced noise on the input lines, use a two-wire shielded cable and connect the shield wire to the negative terminal at a point on the signal source.

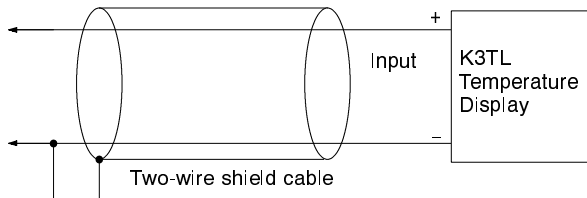

OMRON[®]
OMRON ELECTRONICS, INC.
One East Commerce Drive
Schaumburg, IL 60173
1-800-55-OMRON

OMRON CANADA, INC.
885 Milner Avenue
Scarborough, Ontario M1B 5V8
416-286-6465