

A Wide Variety of DIN 48 x 48-mm H3CR-F Twin Timers, H3CR-G Star-delta Timers, and H3CR-H Power OFF-delay Timers

- Conforms to VDE0435/0110 and approved by UL and CSA.
- Conforms to EMC standards.
- Six-language instruction manual provided.

■ Broad Line-up of H3CR Series

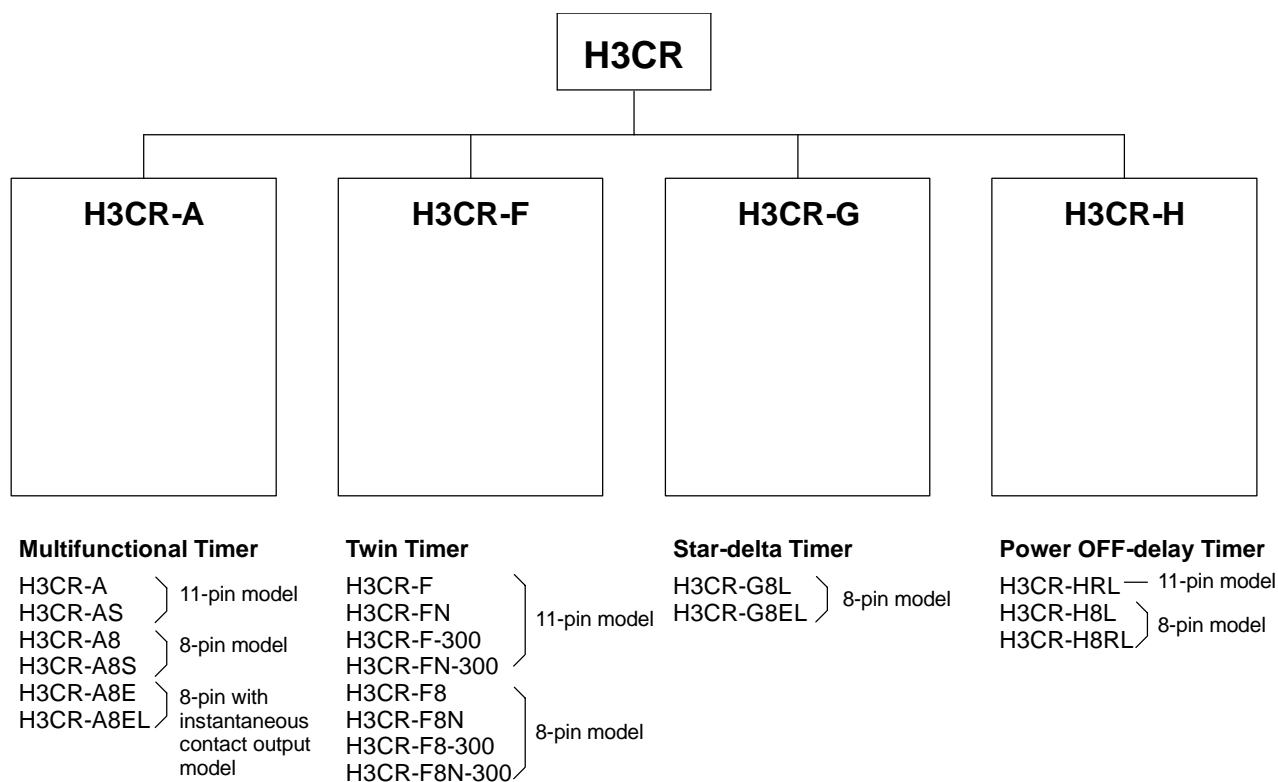

Note: 1. H3CR-AS, H3CR-A8S: Transistor output models
 2. Refer to the *H3CR-A Datasheet (L84)* for details.

Solid-state Twin Timers

H3CR-F

DIN 48 x 48-mm Solid-state Twin Timers

- Wide power supply ranges of 100 to 240 VAC and 48 to 125 VDC respectively.
- Independent ON- and OFF-time settings. Furthermore, combinations of long ON- or OFF-time and short OFF- or ON-time settings are possible.
- Fourteen time ranges from 0.05 s to 30 h or from 1.2 s to 300 h depending on the model to be used.
- Models with a flicker ON start or flicker OFF start are available.
- Easy sequence checks through instantaneous outputs for a zero set value at any time range.
- Only 80 mm long when panel-mounted with a socket.
- 11-pin and 8-pin models are available.

RC

Ordering Information

Operating modes	Supply voltage	0.05 s to 30 h models		1.2 s to 300 h models	
		11-pin models	8-pin models	11-pin models	8-pin models
Flicker OFF start	100 to 240 VAC	H3CR-F	H3CR-F8	H3CR-F-300	H3CR-F8-300
	24 VAC/DC				
	12 VDC				
	48 to 125 VDC				
Flicker ON start	100 to 240 VAC	H3CR-FN	H3CR-F8N	H3CR-FN-300	H3CR-F8N-300
	24 VAC/DC				
	12 VDC				
	48 to 125 VDC				

Note: Specify both the model number and supply voltage when ordering.

Example: H3CR-F 24 VAC/DC

Supply voltage

Model Number Legend:

H3CR - -
 1 2 3 4

1. Classification

F: Twin timers

2. Configuration

None: 11-pin socket

8: 8-pin socket

3. Twin Timer Mode

None: Flicker OFF start

N: Flicker ON start

4. Specified Type

300: Long time range (1.2 s to 300 h) type

■ Ratings

Rated supply voltage (see note)	100 to 240 VAC (50/60 Hz), 12 VDC, 24 VAC/DC (50/60 Hz), 48 to 125 VDC
Operating voltage range	85% to 110% of rated supply voltage; 90% to 110% with 12-VDC models
Power reset	Minimum power-opening time: 0.1 s
Power consumption	100 to 240 VAC: approx. 10 VA; 12 VDC: approx. 1 W; 24 VAC/DC: approx. 2 VA (AC), approx. 1 W (DC); 48 to 125 VDC: approx. 1.5 W
Control outputs	Contact output: 5 A at 250 VAC, resistive load ($\cos\phi = 1$)

Note: A power supply with a ripple of 20% max. (single-phase power supply with full-wave rectification) can be used with each DC Model.

■ Characteristics

Accuracy of operating time	$\pm 0.3\%$ FS max. ($\pm 0.3\%$ FS ± 10 ms in ranges of 1.2 and 3 s)
Setting error	$\pm 5\%$ FS ± 0.05 s max.
Reset time	0.1 s max.
Influence of voltage	$\pm 0.5\%$ FS max. ($\pm 0.5\%$ FS ± 10 ms in ranges of 1.2 and 3 s)
Influence of temperature	$\pm 2\%$ FS max. ($\pm 2\%$ FS ± 10 ms in ranges of 1.2 and 3s)
Insulation resistance	100 M Ω min. (at 500 VDC)
Dielectric strength	2,000 VAC, 50/60 Hz for 1 min (between current-carrying metal parts and exposed non-current-carrying metal parts) 2,000 VAC, 50/60 Hz for 1 min (between control output terminals and operating circuit) 1,000 VAC, 50/60 Hz for 1 min (between contacts not located next to each other)
Impulse withstand voltage	3 kV (between power terminals) for 100 to 240 VAC, 48 to 125 VDC 1 kV for 12 VDC, 24 VAC/DC 4.5 kV (between current-carrying terminal and exposed non-current-carrying metal parts) for 100 to 240 VAC, 48 to 125 VDC 1.5 kV for 12 VDC, 24 VAC/DC
Noise immunity	± 1.5 kV (between power terminals), square-wave noise by noise simulator (pulse width: 100 ns/1 μ s, 1-ns rise) ± 400 V for 12 VDC
Static immunity	Malfunction: 8 kV Destruction: 15 kV
Vibration resistance	Destruction: 10 to 55 Hz with 0.75-mm single amplitude each in three directions Malfunction: 10 to 55 Hz with 0.5-mm single amplitude each in three directions
Shock resistance	Destruction: 980 m/s ² (100G) each in three directions Malfunction: 98 m/s ² (10G) each in three directions
Ambient temperature	Operating: -10°C to 55°C (with no icing) Storage: -25°C to 65°C (with no icing)
Ambient humidity	Operating: 35% to 85%
Life expectancy	Mechanical: 20 million operations min. (under no load at 1,800 operations/h) Electrical: 100,000 operations min. (5 A at 250 VAC, resistive load at 1,800 operations/h)
Case color	Light Gray (Munsell 5Y7/1)
Enclosure ratings	IEC: IP40
Weight	Approx. 100 g

Engineering Data

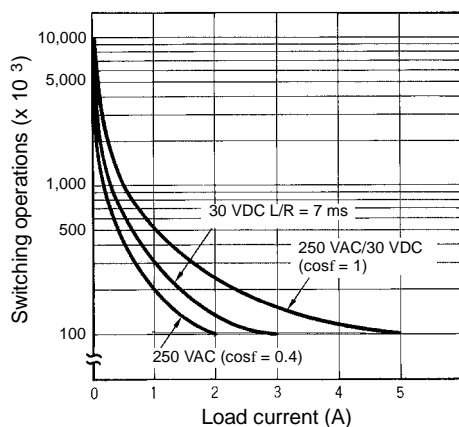

Reference: A maximum current of 0.15 A can be switched at 125 VDC ($\cos\phi = 1$) and a maximum current of 0.1 A can be switched if L/R is 7 ms. In both cases, a life of 100,000 operations can be expected. The minimum applicable load is 10 mA at 5 VDC (failure level: P).

Nomenclature

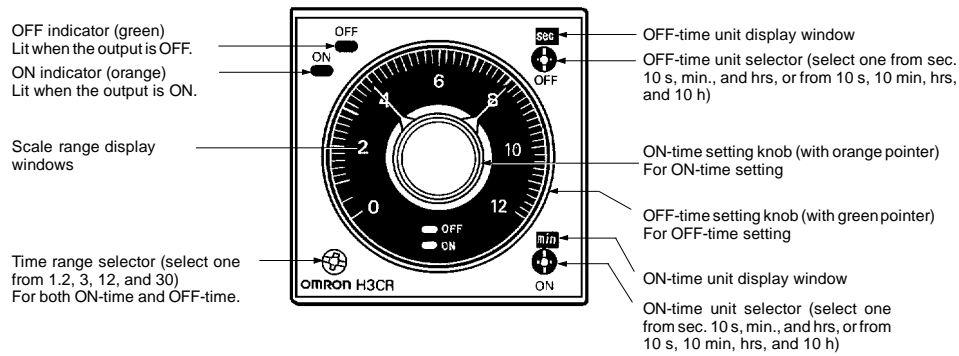

Operation

■ Block Diagrams

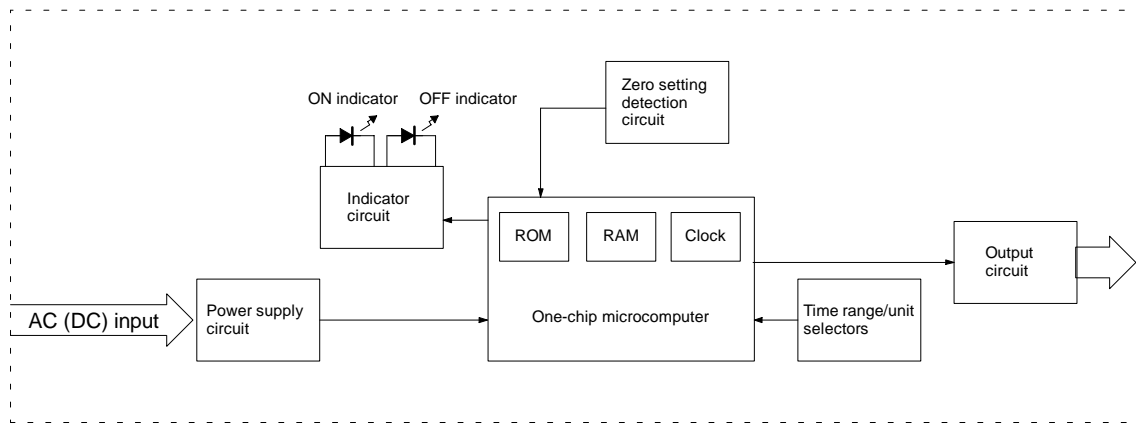

■ I/O Functions

Inputs		---
Outputs	Control output	Outputs are turned ON/OFF according to the time set by the ON- and OFF-time setting knob.

■ Timing Chart

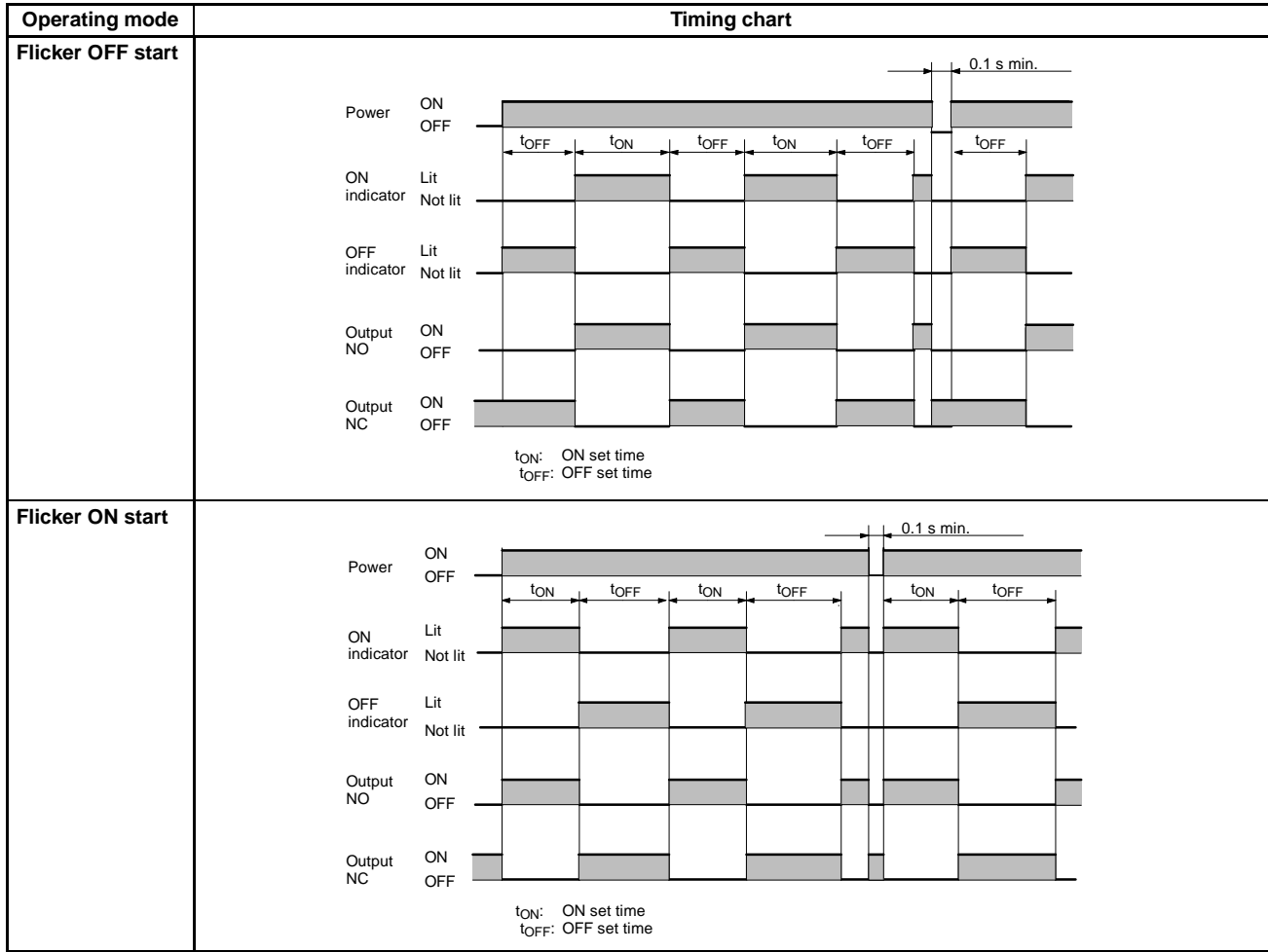

Dimensions

Note: All units are in millimeters unless otherwise indicated.

H3CR-F
H3CR-FN
H3CR-F-300
H3CR-FN-300

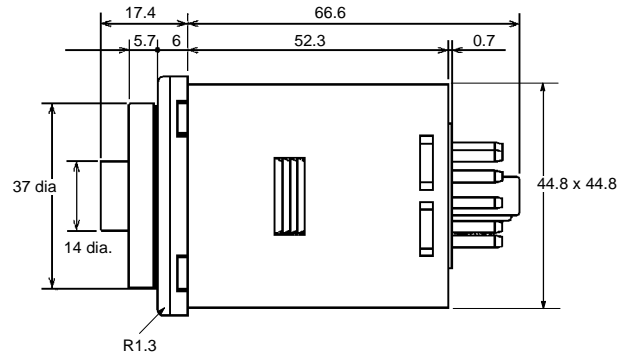
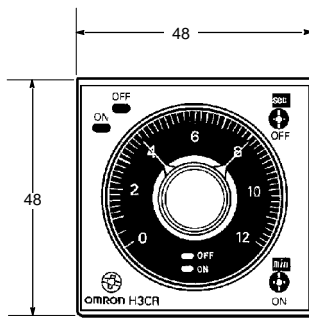
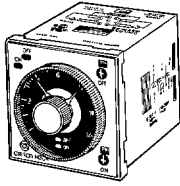

H3CR-F8
H3CR-F8N
H3CR-F8-300
H3CR-F8N-300

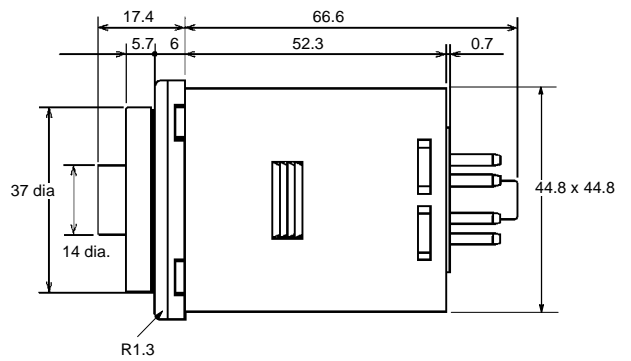
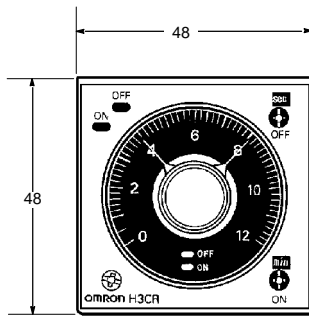
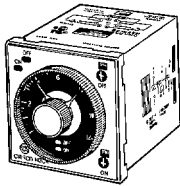

Installation

Terminal Arrangement

H3CR-F8
H3CR-F8N
H3CR-F8-300
H3CR-F8N-300

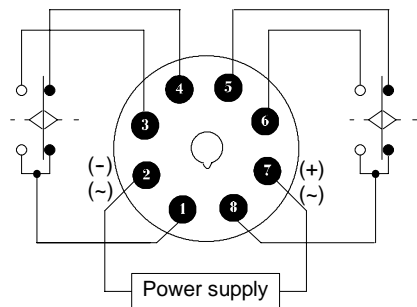

H3CR-F
H3CR-FN
H3CR-F-300
H3CR-FN-300

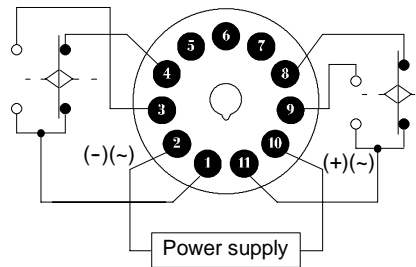

Note: Leave terminals 5, 6, and 7 open.
Do not use them as relay terminals.

Solid-state Star-delta Timer

H3CR-G

DIN 48 x 48-mm Solid-state Star-delta Timer

- A wide star-time range (up to 120 seconds) and star-delta transfer time range (up to 0.5 seconds).

RC

Ordering Information

Outputs	Supply voltage	8-pin models
Time-limit contact	100 to 120 VAC	H3CR-G8L
	200 to 240 VAC	
Time-limit contact and instantaneous contact	100 to 120 VAC	H3CR-G8EL
	200 to 240 VAC	

Note: Specify both the model number and supply voltage when ordering.

Example: H3CR-G8L 100 to 120 VAC

Supply voltage

Model Number Legend:

H3CR -
 1 2 3 4

1. Classification

G: Star-delta timer

2. Configuration

8: 8-pin socket

3. Outputs

None: Star-delta operation contact

E: Star-delta operation contact and instantaneous contact

4. Dimensions

L: Long-body model

■ Accessories (Order Separately)

Name/specifications		Models
Flush Mounting Adapter		Y92F-30
		Y92F-70
		Y92F-71
Mounting Track	50 cm (l) x 7.3 mm (t)	PFP-50N
	1 m (l) x 7.3 mm (t)	PFP-100N
	1 m (l) x 16 mm (t)	PFP-100N2
End Plate		PFP-M
Spacer		PFP-S
Protective Cover		Y92A-48B
Track Mounting/ Front Connecting Socket	8-pin	P2CF-08
Back Connecting Socket		P3G-08
Time Setting Ring	Setting a specific time	Y92S-27
	Limiting the Setting Range	Y92S-28
Panel Cover (see note)	Light Gray (5Y7/1)	Y92P-48GL
	Black (N1.5)	Y92P-48GB
	Medium Gray (5Y5/1)	Y92P-48GM
Hold-down Clip	For PL08 and PL11 Sockets	Y92H-1
	For PF085A Socket	Y92H-2

Note: The Time Setting Ring and Panel Cover are sold together.

Specifications

■ General

Item	H3CR-G8L	H3CR-G8EL
Functions	Star-delta timer	Star-delta timer with instantaneous output
Pin type	8-pin	
Operating/Reset method	Time-limit operation/Self-reset	
Output type	Time-limit: SPST-NO (star operation circuit) SPST-NO (delta operation circuit)	Time-limit: SPST-NO (star operation circuit) SPST-NO (delta operation circuit) Instantaneous: SPST-NO
Mounting method	DIN track mounting, surface mounting, and flush mounting	
EMC	Emission Enclosure: EN55011 Group 1 class A Emission AC Mains: EN55011 Group 1 class A Immunity ESD: IEC801-2: 4 kV contact discharge (level 2) 8 kV air discharge (level 3) Immunity RF-interference: ENV50140: 10 V/m (80 MHz to 1 GHz) (level 3) Immunity Conducted Disturbance: ENV50141: 10 V (0.15 to 80 MHz) (level 3) Immunity Burst: IEC801-4: 2 kV power-line (level 3) 2 kV I/O signal-line (level 4)	
Approved standards	UL508, CSA C22.2 No.14, LR/NK Conforms to VDE0435/2021, VDE0110 Conforms to EN50081-2, prEN50082-2	

■ Time Ranges

Star-delta transfer time		0.05 sec	0.1 sec	0.25 sec	0.5 sec
Star operation time setting	6	0.5 to 6 sec			
	12	1 to 12 sec			
	60	5 to 60 sec			
	120	10 to 120 sec			

■ Ratings

Rated supply voltage	100 to 120 VAC (50/60 Hz), 200 to 240 VAC (50/60 Hz)
Operating voltage range	85% to 110% of rated supply voltage
Power reset	Minimum power-opening time: 0.5 s
Power consumption	100 to 120 VAC: approx. 6 VA/2.4 W 200 to 240 VAC: approx. 12 VA/2.6 W
Control outputs	Contact output: 5 A at 250 VAC, resistive load ($\cos\phi = 1$)

■ Characteristics

Accuracy of operating time	±0.3% FS max.
Setting error	±5% FS ±0.05 s max.
Star-delta transfer time	Accuracy: ±25% FS + 5 ms max.
Influence of voltage	±0.5% FS max.
Influence of temperature	±2% FS max.
Insulation resistance	100 M Ω min. (at 500 VDC)
Dielectric strength	2,000 VAC, 50/60 Hz for 1 min (between current-carrying metal parts and exposed non-current-carrying metal parts) 2,000 VAC, 50/60 Hz for 1 min (between control output terminals and operating circuit) 1,000 VAC, 50/60 Hz for 1 min (between contacts not located next to each other)
Impulse withstand voltage	3 kV (between power terminals) 4.5 kV (between current-carrying terminal and exposed non-current-carrying metal parts)
Noise immunity	±1.5 kV (between power terminals), square-wave noise by noise simulator (pulse width: 100 ns/1 μ s, 1-ns rise)
Static immunity	Malfunction: 8 kV Destruction: 15 kV
Vibration resistance	Destruction: 10 to 55 Hz with 0.75-mm single amplitude each in three directions Malfunction: 10 to 55 Hz with 0.5-mm single amplitude each in three directions
Shock resistance	Destruction: 980 m/s ² (100G) each in three directions Malfunction: 294 m/s ² (30G) each in three directions
Ambient temperature	Operating: -10°C to 55°C (with no icing) Storage: -25°C to 65°C (with no icing)
Ambient humidity	Operating: 35% to 85%
Life expectancy	Mechanical: 20 million operations min. (under no load at 1,800 operations/h) Electrical: 100,000 operations min. (5 A at 250 VAC, resistive load at 1,800 operations/h)
Case color	Light Gray (Munsell 5Y7/1)
Enclosure ratings	IEC: IP40
Weight	H3CR-G8L: approx. 110 g; H3CR-G8EL: approx. 130 g

Engineering Data

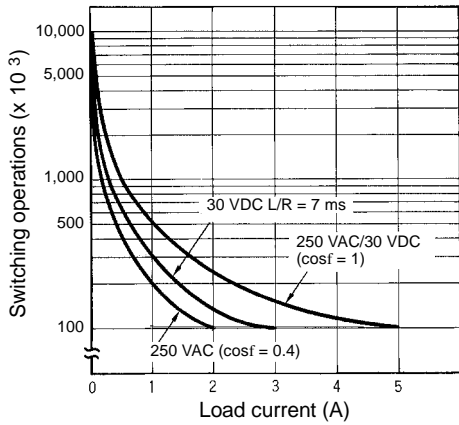

Reference: A maximum current of 0.15 A can be switched at 125 VDC (cosφ = 1) and a maximum current of 0.1 A can be switched if L/R is 7 ms. In both cases, a life of 100,000 operations can be expected. The minimum applicable load is 10 mA at 5 VDC (failure level: P).

Nomenclature

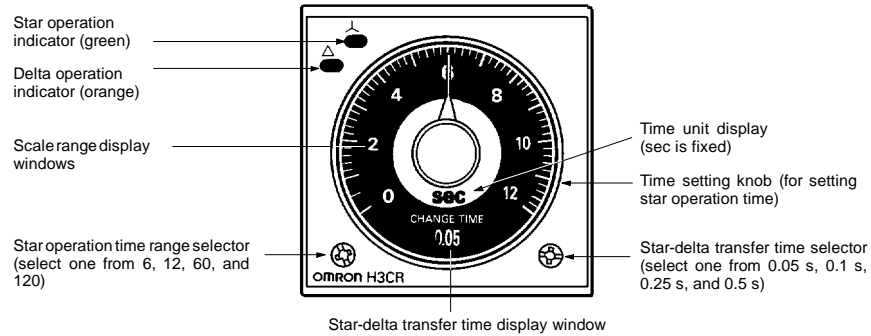

Operation

■ Block Diagrams

H3CR-G8L

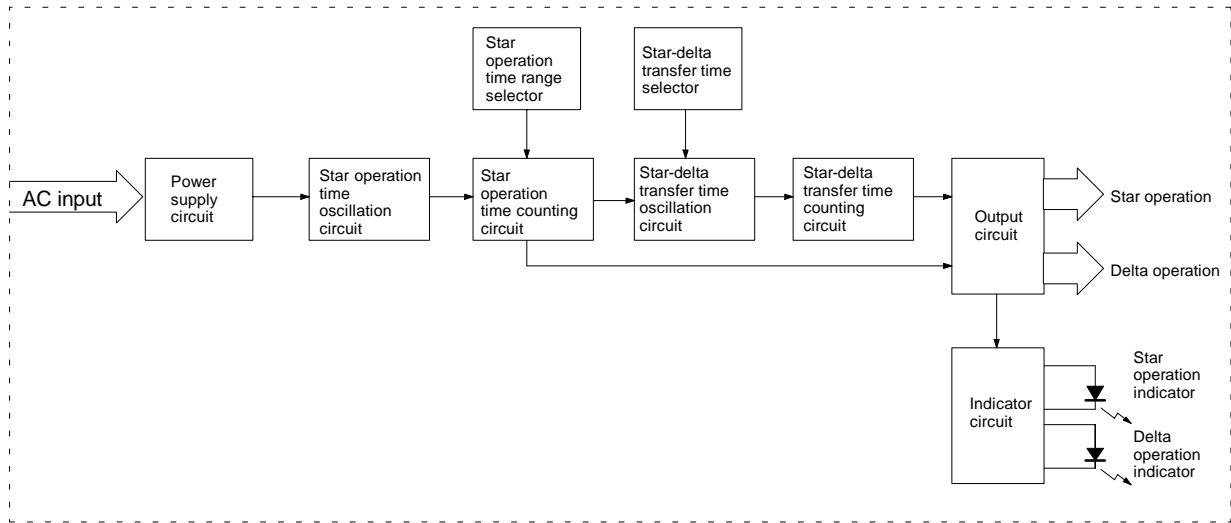

H3CR-G8EL

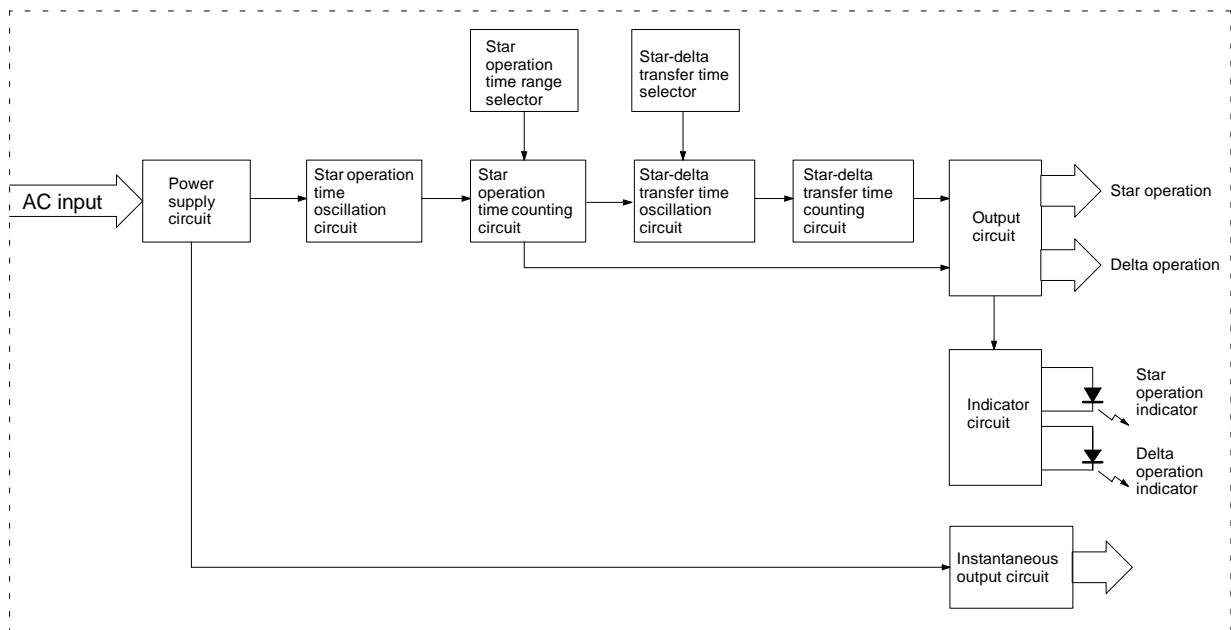

■ I/O Functions

Inputs		---
Outputs	Control output	If the time reaches the value set with the time setting knob, the star operation output will be turned OFF and there will be delta operation output after the set star-delta transfer time has elapsed.

■ Using the Setting Ring

Setting a Specific Time

Mount the Panel Cover on the Timer, set the desired time with the time setting knob, and place Time Setting Ring A onto the time setting knob so that the time setting notch of Time Setting Ring A is in the center of the reset lock position of the Panel Cover.

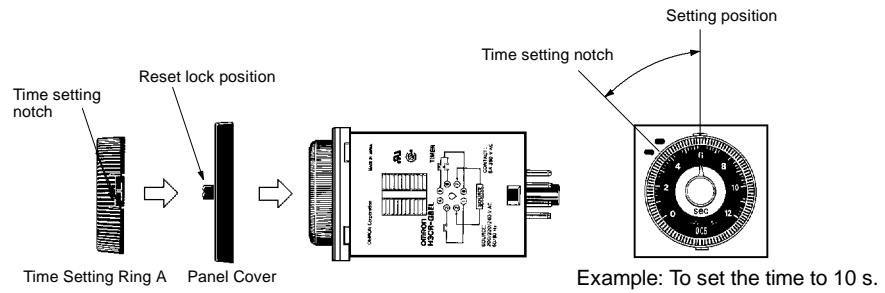

Limiting the Setting Range

Example: To set a range of 10 and 20 s.

Mount the Panel Cover on the Timer, set the time setting knob to 10 s (the lower limit of the setting range), and place Time Setting Ring C on the time setting knob so that the stopper of Time Setting Ring C is on the right edge of the reset lock position of the Panel cover. Next, set the time setting knob to 20 s (the upper limit of the setting range), place Time Setting Ring B on the time setting knob so that the stopper of Time Setting Ring B is on the left edge of the reset lock position of the Panel Cover.

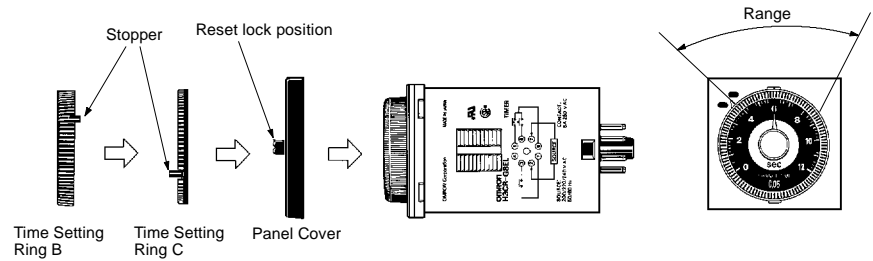

■ Timing Chart

Model	Timing chart		
H3CR-G8L/-G8EL	Power (2 - 7)	ON OFF	
	Instantaneous output (1 - 3) (-E models)	ON OFF	
	Star operation output (8 - 5)	ON OFF	
	Delta operation output (8 - 6)	ON OFF	
	Star operation indicator	Lit Not lit	
	Delta operation indicator	Lit Not lit	

Note: t1: Star operation time setting
t2: Star-delta transfer time

Dimensions

Note: All units are in millimeters unless otherwise indicated.

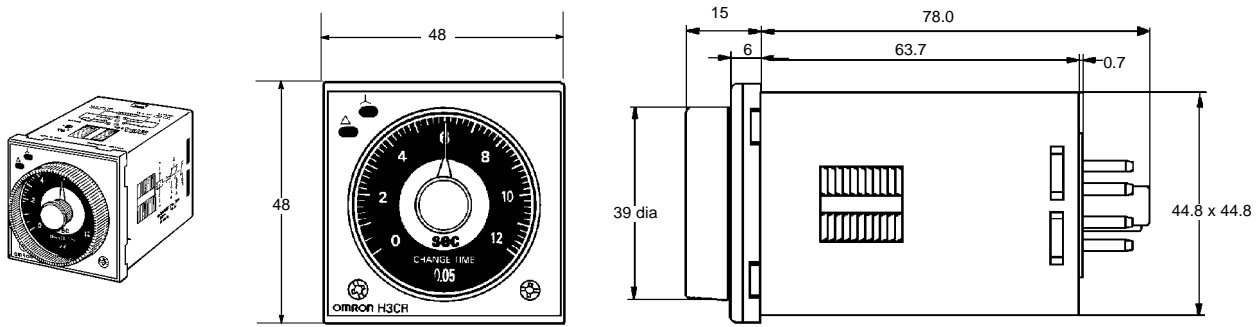

Dimensions with Set Ring

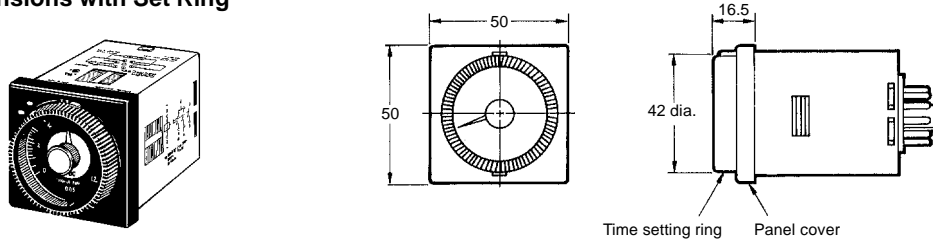

Time Setting Ring/Panel Cover

There are three types of Panel Covers (Y92P-48GL, Y92P-48GB, and Y92P-48GM), all of which are available in three colors. Use the most suitable type of Panel Cover with the design of the scaling plate according to the application.

When setting a given time for the Timer, use of the Y92S-27 or Y92S-28 Time Setting Ring facilitates the time setting operation and minimizes possible setting errors by operators.

The Time Setting Ring and Panel Cover should be used as a pair.

Setting a specific time	Time Setting Ring A (Y92S-27) and Panel Cover (Y92P-48GL, -48GB, or -48GM)
Limiting the setting range	Time Setting Ring B or C (Y92S-28), and Panel Cover (Y92P-48GL, -48GB, or -48GA)

**Y92S-27
Time Setting A**



**Y92P-48GL
Light Gray**

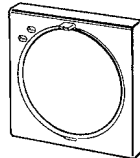

**Y92S-28
Time Setting B**



**Y92P-48GB
Black**

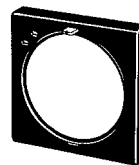

**Y92S-28
Time Setting C**



**Y92P-48GM
Medium Gray**

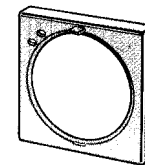

Installation

■ Terminal Arrangement

H3CR-G8L

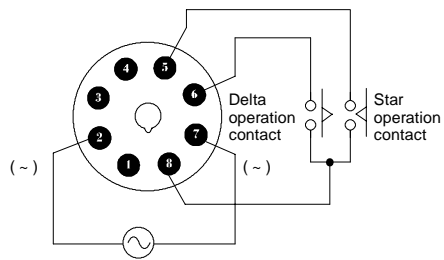

Note: Leave terminals 1, 3, and 4 open.
Do not use them as relay terminals.

H3CR-G8EL

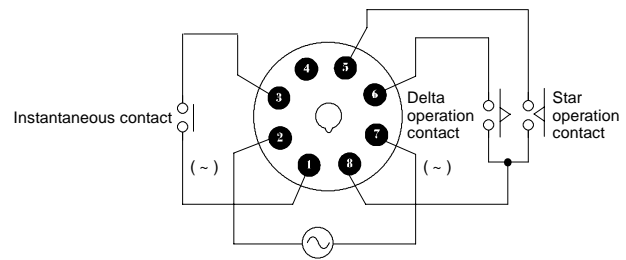

Note: Leave terminal 4 open. Do not use
them as relay terminals.

Solid-state Power OFF-delay Timer

H3CR-H

DIN 48 x 48-mm Solid-state Power OFF-delay Timer

- Long power OFF-delay times;
S-series: up to 12 seconds,
M-series: up to 12 minutes.
- Models with forced-reset input are available.
- 11-pin and 8-pin models are available.

RC

Ordering Information

Input	Output	Supply voltage	S-series		M-series	
			11-pin models	8-pin models	11-pin models	8-pin models
With reset input	DPDT	100 to 120 VAC	---	H3CR-H8L	---	H3CR-H8L
		200 to 240 VAC				
		24 VAC/DC				
		48 VDC				
		100 to 125 VDC				
	SPDT	100 to 120 VAC	H3CR-H8RL	---	H3CR-H8RL	---
		200 to 240 VAC				
		24 VAC/DC				
		48 VDC				
		100 to 125 VDC				

Note: Specify both the supply voltage and time unit code (S or M) in addition to the model number when ordering.

Example: H3CR-H8L 24 VAC/DC M

Time unit code

Supply voltage

Model Number Legend:

H3CR -
1 2 3 4

1. Classification

H: Power OFF-delay timer

2. Configuration

None: 11-pin socket

8: 8-pin socket

3. Input

None: Without reset input

R: With reset input

4. Dimensions

L: Long-body model

■ Accessories (Order Separately)

Name/specifications		Models
Flush Mounting Adapter		Y92F-30
		Y92F-70
		Y92F-71
Mounting Track	50 cm (l) x 7.3 mm (t)	PFP-50N
	1 m (l) x 7.3 mm (t)	PFP-100N
	1 m (l) x 16 mm (t)	PFP-100N2
End Plate		PFP-M
Spacer		PFP-S
Protective Cover		Y92A-48B
Track Mounting/ Front Connecting Socket	8-pin	P2CF-08
	11-pin	P2CF-11
Back Connecting Socket	8-pin	P3G-08
	11-pin	P3GA-11
Hold-down Clip	For PL08 and PL11 Sockets	Y92H-1
	For PF085A Socket	Y92H-2

Specifications

■ General

Item	H3CR-H8L	H3CR-H8RL	H3CR-HRL
Operating/Reset method	Instantaneous operation/Time-limit reset	Instantaneous operation/Time-limit reset/Forced reset	
Pin type	8-pin		11-pin
Input type	---		No-voltage
Output type	Relay output (DPDT)	Relay output (SPDT)	Relay output (DPDT)
Mounting method	DIN track mounting, surface mounting, and flush mounting		
EMC	Emission Enclosure: Emission AC Mains: Immunity ESD: Immunity RF-interference: Immunity Conducted Disturbance: Immunity Burst:	EN55011 Group 1 class A EN55011 Group 1 class A IEC801-2: 4 kV contact discharge (level 2) 8 kV air discharge (level 3) ENV50140: 10 V/m (80 MHz to 1 GHz) (level 3) ENV50141: 10 V (0.15 to 80 MHz) (level 3) IEC801-4: 2 kV power-line (level 3) 2 kV I/O signal-line (level 4)	
Approved standards	UL508, CSA C22.2 No.14, LR/NK Conforms to VDE0435/2021, VDE0110 Conforms to EN50081-2, prEN50082-2		

■ Time Ranges

Time unit		S-series	M-series
		s (sec)	min
Setting	0.6	0.05 to 0.6	
	1.2	0.1 to 1.2	
	6	0.5 to 6	
	12	1 to 12	
Min. power ON time		0.1 sec min.	2 sec min.

Note: If the above minimum power ON time is not secured, the H3CR may not operate. Be sure to secure the above minimum power ON time.

■ Ratings

Rated supply voltage (see note)	100 to 120 VAC (50/60 Hz), 200 to 240 VAC (50/60 Hz), 24 VAC/VDC (50/60 Hz), 48 VDC, 100 to 125 VDC
Operating voltage range	85% to 110% of rated supply voltage
No-voltage input	ON-impedance: 1 k Ω max. ON residual voltage: 1 V max. OFF impedance: 500 k Ω min.
Power consumption	100 to 120 VAC: 0.18 VA (100 VAC applied) 200 to 240 VAC: 0.25 VA (200 VAC applied) 24 VAC/DC: 0.24 VA (24 VAC applied)/140 mW (24 VDC applied) 48 VDC: 130 mW (48 VDC applied) 100 to 125 VDC: 330 mW (125 VDC applied)
Control outputs	Contact output: 5 A at 250 VAC, resistive load ($\cos\phi = 1$)

Note: A power supply with a ripple of 20% max. (single-phase power supply with full-wave rectification) can be used with each DC Model.

■ Characteristics

Accuracy of operating time	$\pm 0.3\%$ FS max. ($\pm 0.3\%$ FS ± 10 ms in ranges of 0.6 and 1.2 s)
Setting error	$\pm 5\%$ FS ± 0.05 s max.
Influence of voltage	$\pm 0.5\%$ FS max. ($\pm 0.5\%$ FS ± 10 ms in ranges of 0.6 and 1.2 s)
Influence of temperature	$\pm 2\%$ FS max. ($\pm 2\%$ FS ± 10 ms in ranges of 0.6 and 1.2 s)
Insulation resistance	100 MW min. (at 500 VDC)
Dielectric strength	2,000 VAC, 50/60 Hz for 1 min (between current-carrying metal parts and exposed non-current-carrying metal parts) 2,000 VAC, 50/60 Hz for 1 min (between control output terminals and operating circuit) 1,000 VAC, 50/60 Hz for 1 min (between contacts not located next to each other)
Impulse withstand voltage	3 kV (between power terminals) for 100 to 120 VAC, 200 to 240 VAC, 100 to 125 VDC; 1 kV for 24 VAC/DC, 48 VDC 4.5 kV (between current-carrying terminal and exposed non-current-carrying metal parts) for 100 to 120 VAC, 200 to 240 VAC, 100 to 125 VDC; 1.5 kV for 24 VAC/DC, 48 VDC
Noise immunity	± 1.5 kV (between power terminals) and ± 600 V (between input terminals), square-wave noise by noise simulator (pulse width: 100 ns/1 ms, 1-ns rise); ± 1 kV (between power terminals) for 48 VDC
Static immunity	Malfunction: 8 kV Destruction: 15 kV
Vibration resistance	Destruction: 10 to 55 Hz with 0.75-mm single amplitude each in three directions Malfunction: 10 to 55 Hz with 0.5-mm single amplitude each in three directions
Shock resistance	Destruction: 980 m/s ² (100G) each in three directions Malfunction: 98 m/s ² (10G) each in three directions
Ambient temperature	Operating: -10°C to 55°C (with no icing) Storage: -25°C to 65°C (with no icing)
Ambient humidity	Operating: 35% to 85%
Life expectancy	Mechanical: 10 million operations min. (under no load at 1,200 operations/h) Electrical: 100,000 operations min. (5 A at 250 VAC, resistive load at 1,200 operations/h)
Case color	Light Gray (Munsell 5Y7/1)
Enclosure ratings	IEC: IP40
Weight	Approx. 120 g

Engineering Data

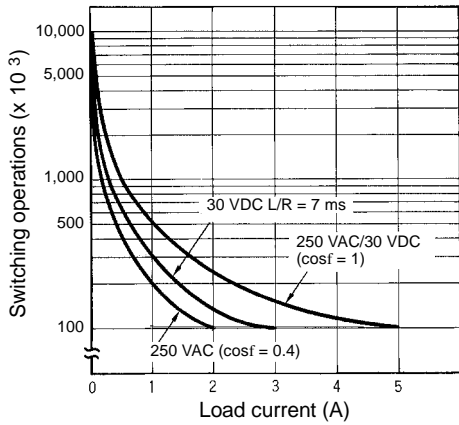

Reference: A maximum current of 0.15 A can be switched at 125 VDC (cosφ = 1) and a maximum current of 0.1 A can be switched if L/R is 7 ms. In both cases, a life of 100,000 operations can be expected. The minimum applicable load is 10 mA at 5 VDC (failure level: P).

Nomenclature

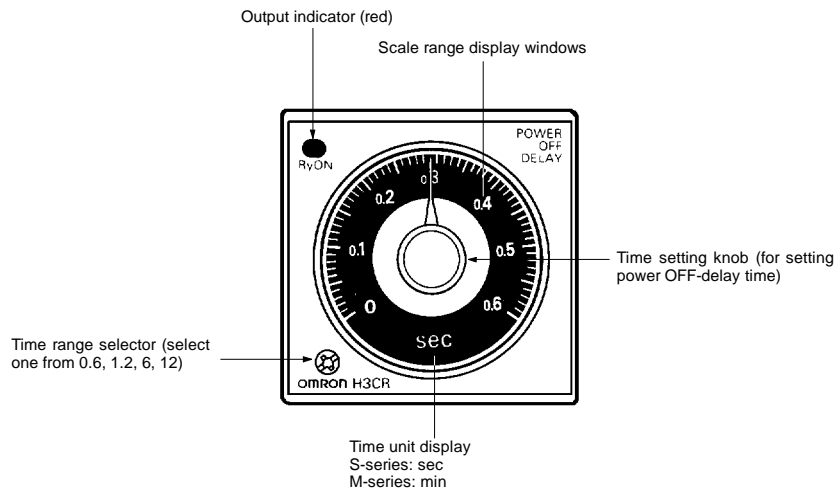

Operation

■ Block Diagrams

Without Reset Input (H3CR-H8L)

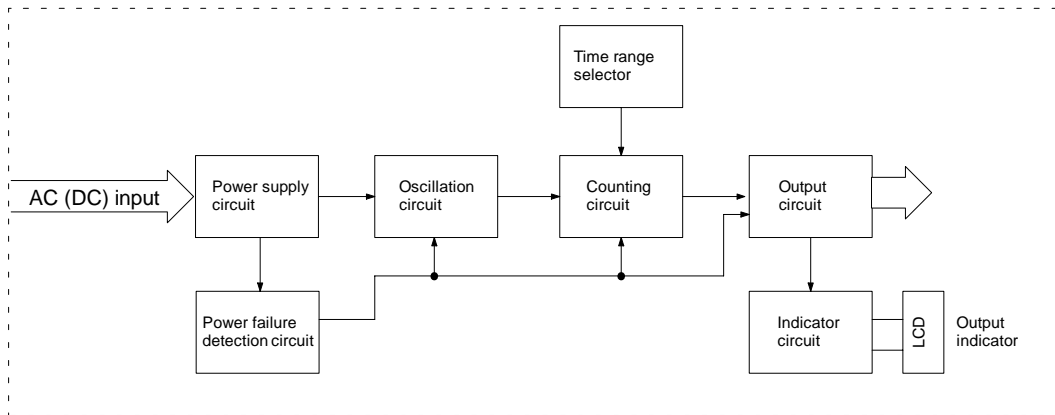

With Reset Input (H3CR-H8RL/-HRL)

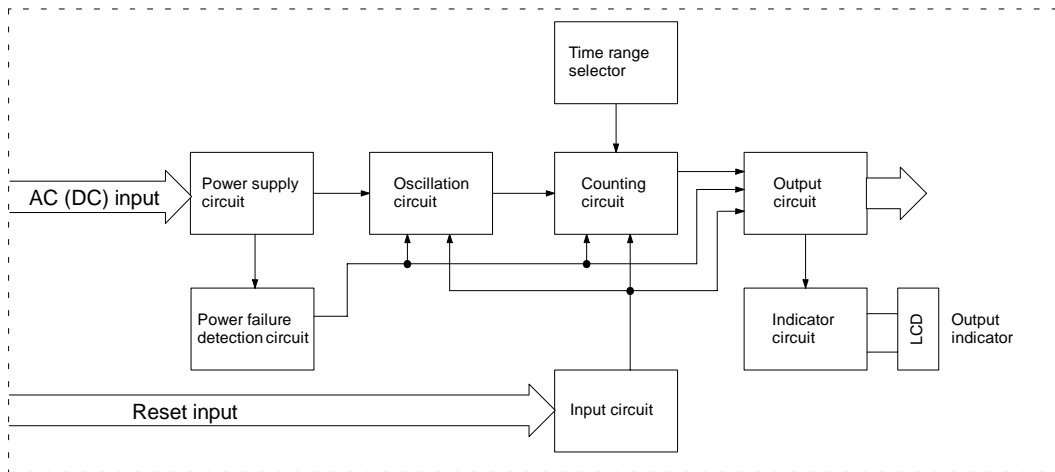

■ I/O Functions

Inputs	Reset	Turns off the control output and resets the elapsed time.
Outputs	Control output	Operates instantaneously when the power is turned on and time-limit resets when the set time is up after the power is turned off.

■ Timing Chart

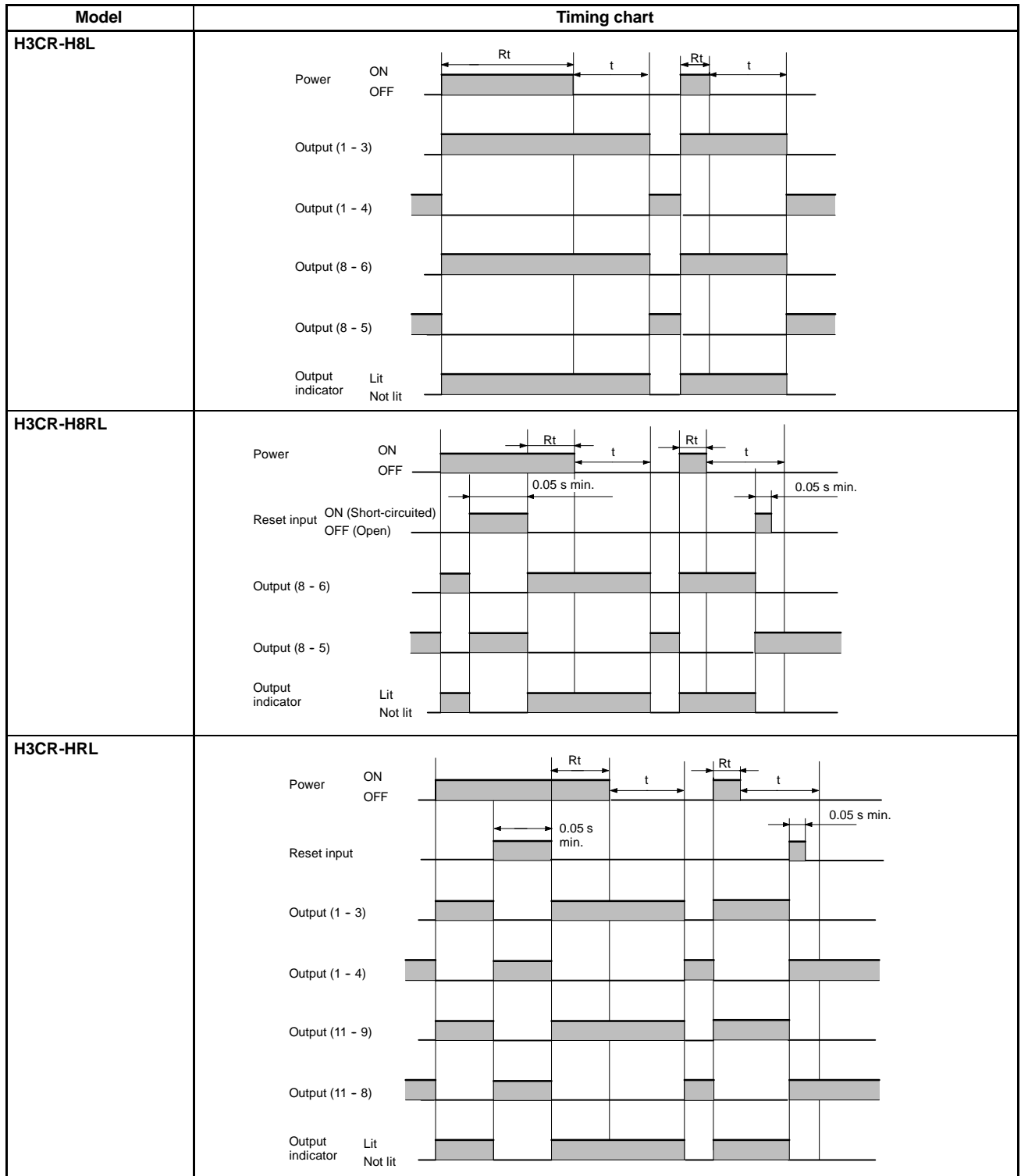

Note: t: Set time
 Rt: Minimum power ON time (S-series: 0.1 s min.; M-series: 2 s min.)

Dimensions

Note: All units are in millimeters unless otherwise indicated.

H3CR-H8L
H3CR-H8RL

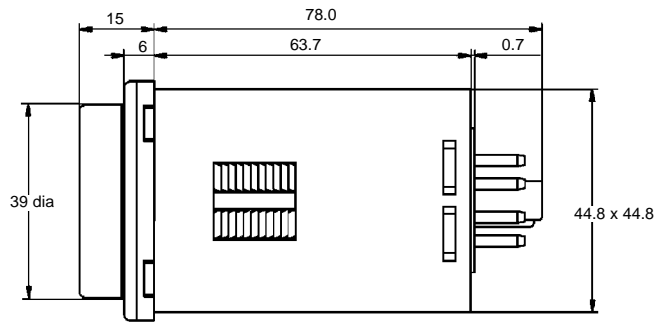
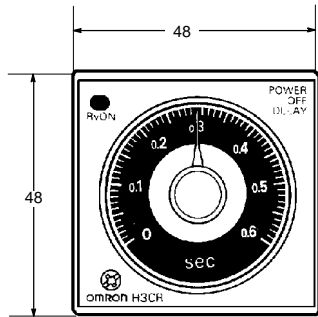
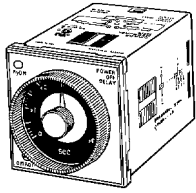

H3CR-HRL

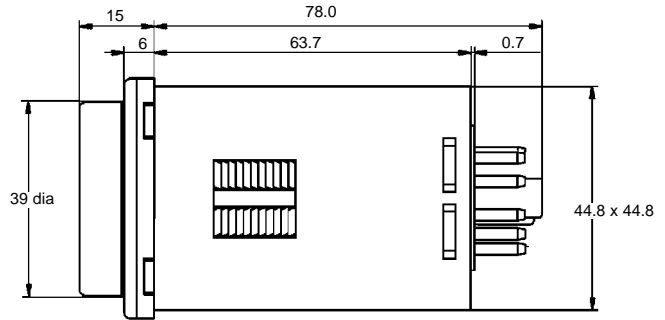
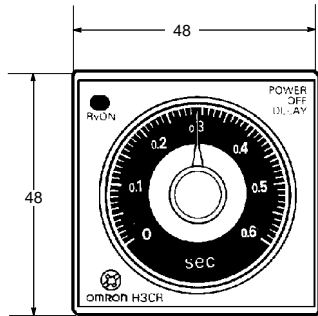
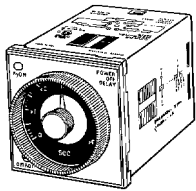

Installation

Terminal Arrangement

8-pin Models

Without Reset Input (H3CR-H8L)

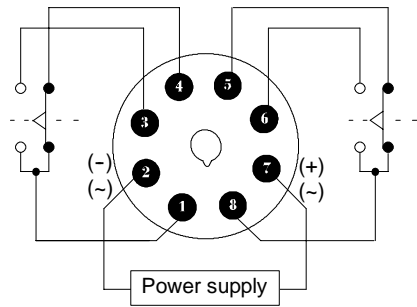

With Reset Input (H3CR-H8RL)

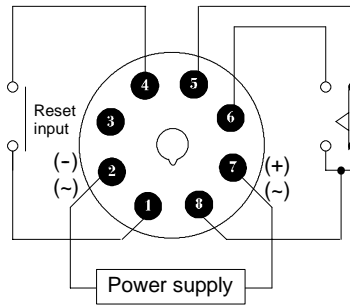

Note: Leave terminal 3 open. Do not use them as relay terminals.

11-pin Model

With Reset Input (H3CR-HRL)

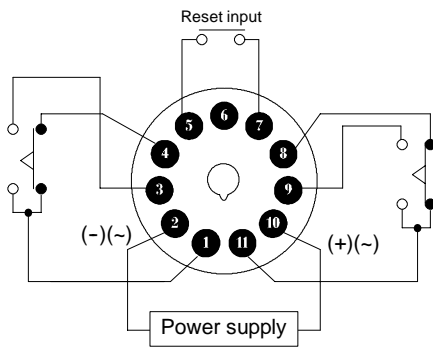

Note: Leave terminal 6 open. Do not use them as relay terminals.

Operation

Note: The undermentioned is common for all H3CR-F/G/H models.

Basic Setting

Setting of Selectors

The selectors can be turned clockwise and counterclockwise to select the desired time unit, time range, or operating mode. Each selector has a snap mechanism that secures the selector at a given position. Set the selector at a position at which it is secured. Do not set it midway between two securing positions or a malfunction could result from improper setting.

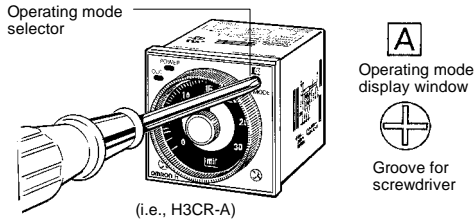

For OFF-time, the desired time unit (sec, 10 s, min, and hrs, or 10 s, 10 min, hrs, and 10 h) is indicated in the OFF-time unit display window at the upper right corner of the front panel and can be changed by turning the OFF-time unit selector located below the OFF-time unit display window.

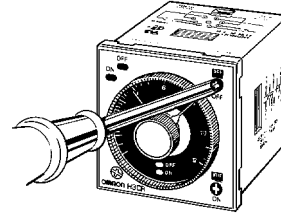

H3CR-G Star-delta Timers

A star operation time range (0 to 6, 0 to 12, 0 to 60, or 0 to 120 seconds) is selected with the star operation time range selector at the lower left corner of the front panel.

Selection of Time Unit and Time Range

H3CR-F Twin Timers

A time range (0 to 1.2, 0 to 3, 0 to 12, or 0 to 30) is selected for ON- and OFF-time using the time range selector at the lower left corner of the front panel, and the selected time range appears within the plastic frame of the time setting knob (= scale range display windows).

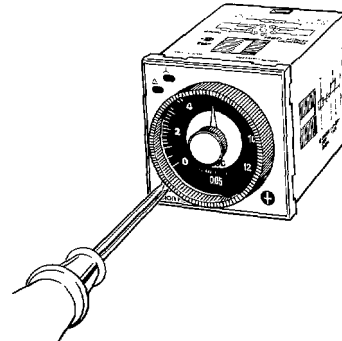
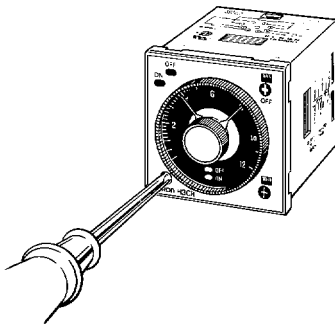

The time required for switching (0.05, 0.1, 0.25, or 0.5 second) from the star operation to the delta operation of the H3CR-G can be selected with the star-delta transfer time selector at the lower right corner of the front panel.

For ON-time, the desired time unit (sec, 10 s, min, and hrs, or 10 s, 10 min, hrs, and 10 h) is indicated in the ON-time unit display window at the lower right corner of the front panel and can be changed by turning the ON-time unit selector located below the ON-time unit display window.

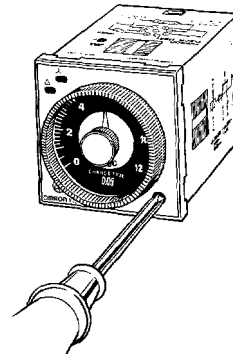
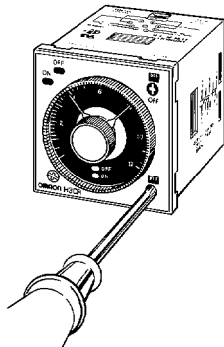

• H3CR-H Power OFF-delay Timers

A time range (0 to 0.6, 0 to 1.2, 0 to 6, and 0 to 12) is selected with the time range selector at the lower left corner of the front panel. No time unit selector is available. When ordering the H3CR-H, specify S (for the second unit) or M (for the minute unit) for your H3CR-H.

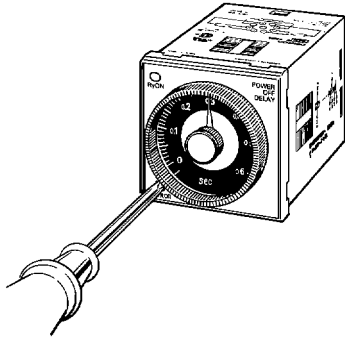

Dimensions

Note: The undermentioned is common for all H3CR-F/G/H models.

Note: All units are in millimeters unless otherwise indicated.

Dimensions with Flush Mounting Adaptor Y92F-30

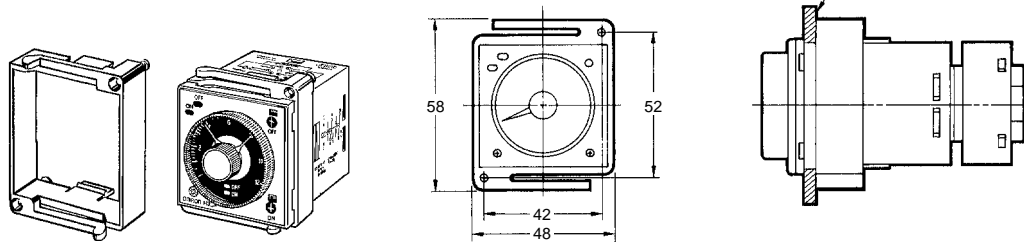

Note: The adapters for two or more timers mounted in a vertical line are different in orientation from those mounted in a horizontal line.

N can be obtained as follows (n: the number of H3CR models arranged side by side)

Without a Cover: $N = (48n - 2.5) \text{ }^{+1}_{-0}$

With the Protective Cover: $N = (51n - 5.5) \text{ }^{+1}_{-0}$

With the Panel Cover: $N = (50n - 4.5) \text{ }^{+1}_{-0}$

Panel Cutout

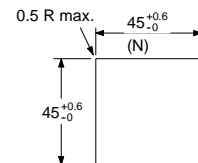

**Dimensions with Flush Mounting Adaptor
Y92F-73/-70**

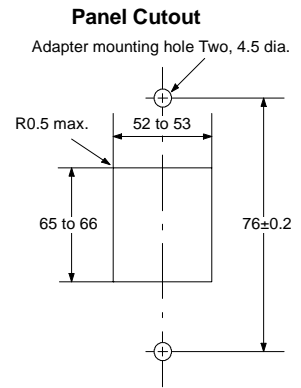
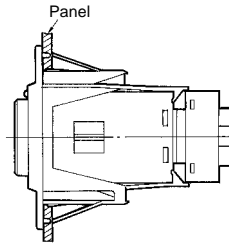
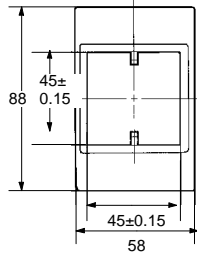
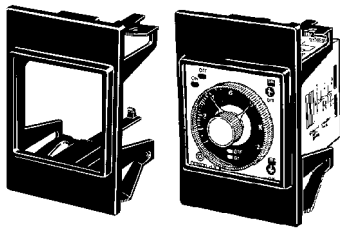

Note: The mounting panel thickness should be 1 to 3.2 mm.

**Dimensions with Flush Mounting Adaptor
Y92F-74/-71**

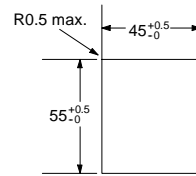
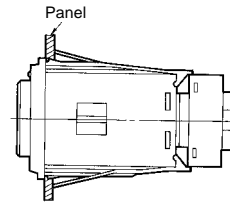
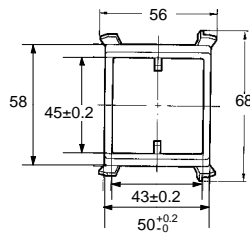
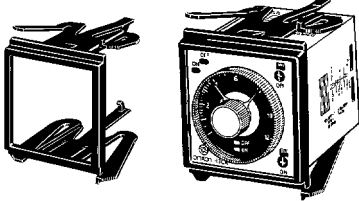

Note: The mounting panel thickness should be 1 to 3.2 mm.

Track Mounting

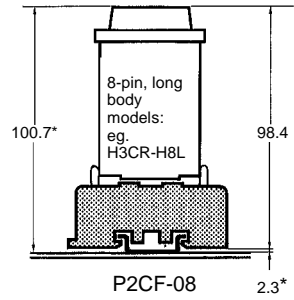
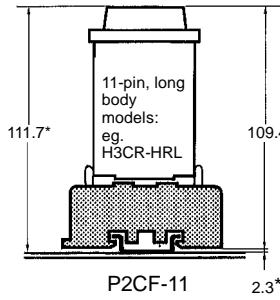
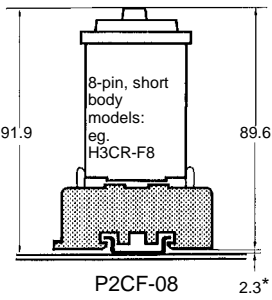
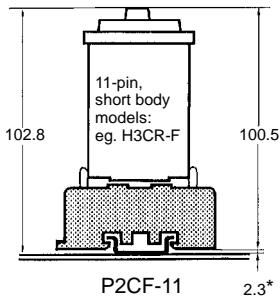

*These dimensions vary with the kind of DIN track (reference value).

Flush Mounting

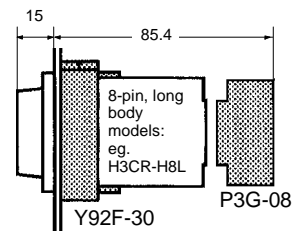
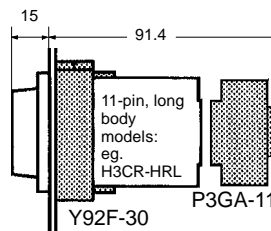
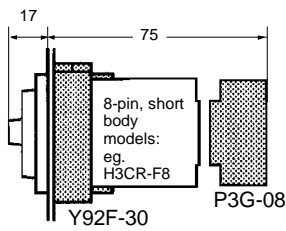
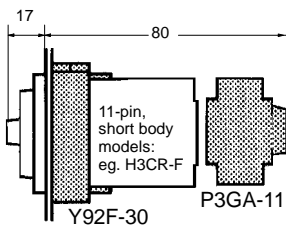

■ Accessories (Order Separately)

**Track Mounting/
Front Connecting Socket
P2CF-08**

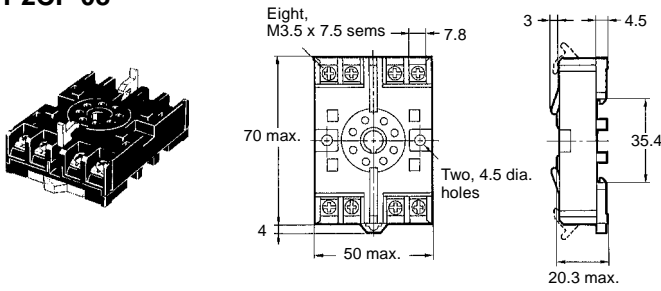

**Terminal Arrangement/
Internal Connections
(Top View)**

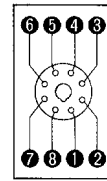

Surface Mounting Holes

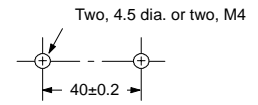

P2CF-11

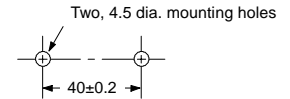
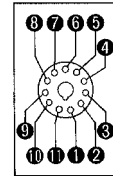
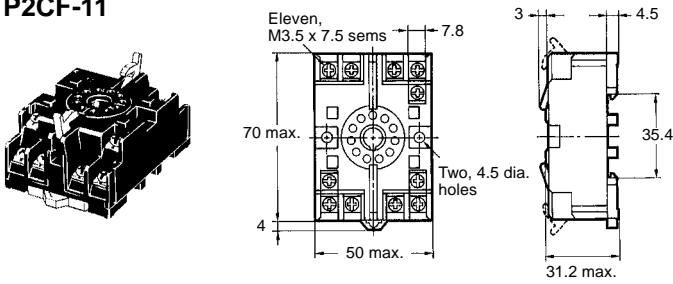

**Back Connecting Socket
P3G-08**

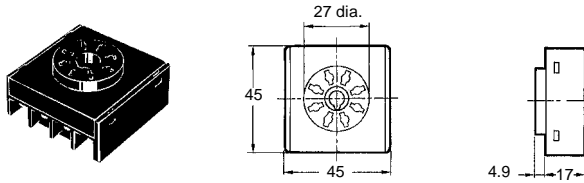

**Terminal Arrangement/
Internal Connections
(Bottom View)**

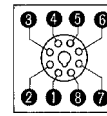

P3GA-11

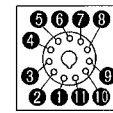
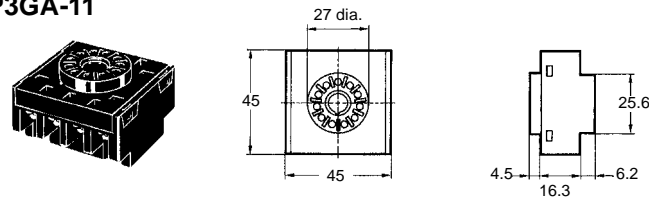

**Mounting Track
PFP-100N, PFP-50N**

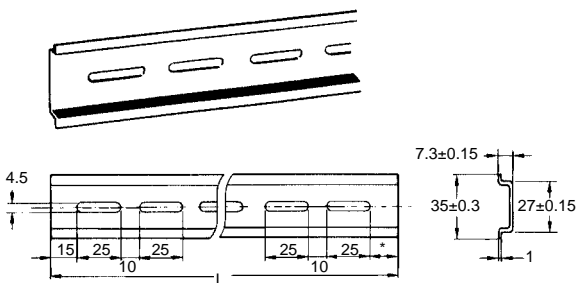

PFP-100N2

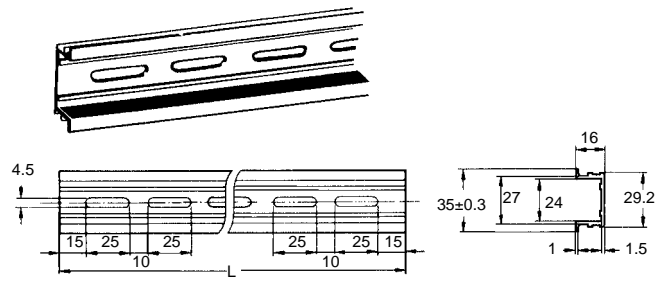

L: Length

1 m	PFP-100N
50 cm	PFP-50N
1 m	PFP-100N2

End Plate
PFP-M

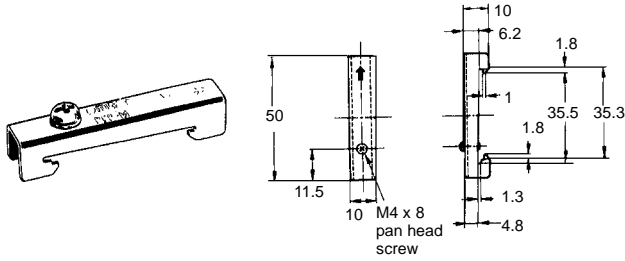

Spacer
PFP-S

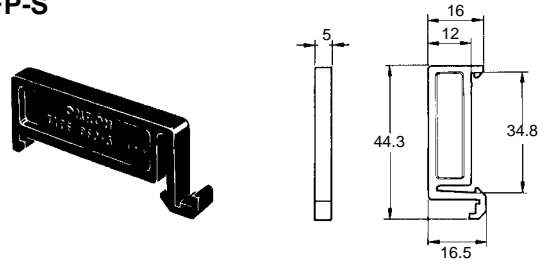

Protective Cover
Y92A-48B

The protective cover protects the front panel, particularly the time setting section, against dust, dirt, and water. It also prevents the set value from being altered due to accidental contact with the time setting knob.

- Note:**
1. The Y92A-48B Protective Cover is made of a hard plastic and therefore it must be removed to change the timer set value.
 2. The Protective Cover cannot be mounted if the Panel Cover (sold separately) is used on the Timer.

Y92A-48B

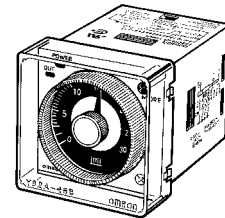

Hold-down Clip

Y92H-7/-1
For PL08 and PL11 Sockets

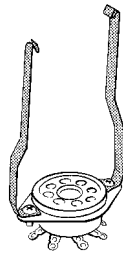

Y92H-8/-2
For PF085A Socket

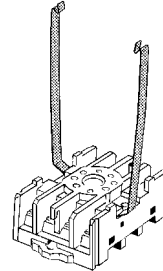

Precautions

Note: The undermentioned is common for all H3CR-F/G/H models.

■ Changing of Setting

NOTICE: Do not change the time unit, time range, or operation mode while the timer is in operation or malfunction could result.

■ Wiring (H3CR-H)

The H3CR has a high impedance circuit. Therefore, the H3CR may not be reset if the H3CR is influenced by inductive voltage. In order to eliminate any influence of inductive voltage, the wires connected to the H3CR must be as short as possible and should not be installed alongside power lines. If the H3CR is influenced by inductive voltage that is 30% or more of the rated voltage, connect a CR filter with a capacitance of approximately 0.1 μF and a resistance of approximately 120 Ω or a bleeder resistor between the power supply terminals. If there is any residual voltage due to current leakage, connect a bleeder resistor between the power supply terminals.

■ Operation (H3CR-H)

An interval of 3 s minimum is required to turn on the H3CR after the H3CR is turned off. If the H3CR is turned on and off repeatedly with an interval of shorter than 3 s, the internal parts of the H3CR may deteriorate and the H3CR may malfunction.

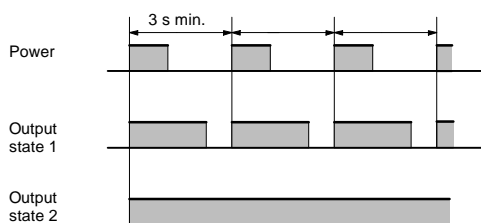

After the forced reset function of the H3CR is activated, an interval of 3 s minimum is required to activate the forced reset function again. If the forced reset function is activated repeatedly with an interval of shorter than 3 s, the internal parts of the H3CR may deteriorate and the H3CR may malfunction.

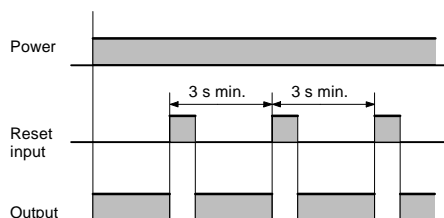

If it is required that the output be turned on repeatedly with an interval of shorter than 3 s, consider use of the H3CR-A in mode D (signal OFF-delay).

■ Power Supplies (H3CR-H)

An AC power supply can be connected to the power input terminals without regarding polarity. A DC power supply must be connected to the power input terminals as designated according to the polarity of the terminals.

A DC power supply can be connected if its ripple factor is 20% or less and the mean voltage is within the rated operating voltage range of the Timer.

Connect the power supply voltage through a relay or switch in such a way that the voltage reaches a fixed value at once or the Timer may not be reset or a timer error could result.

For the power supply of an input device, use an isolating transformer, of which the primary and secondary windings are mutually isolated and the secondary winding is not grounded.

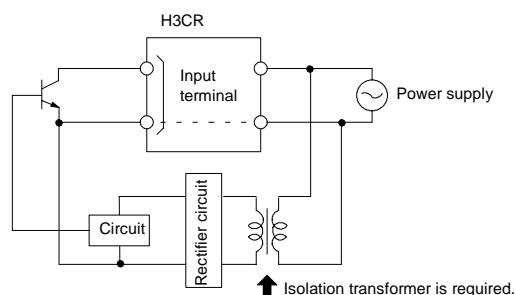

The H3CR-H has a large inrush current; provide sufficient power supply capacity. If the power supply capacity is too small, there may be delays in turning ON the output.

The power supply circuit of any H3CR-Fj 100-to-240-VAC model, and H3CR-Gj 100/110/120-VAC and 200/220/240-VAC model is a switching circuit. If the power line connected to the power supply circuit has a transformer with high inductance, a counter-electromotive voltage will be induced by the inductance. To suppress the voltage, apply a CR filter to the power supply line.

■ Inrush Current

Model		Voltage	Applied voltage	Inrush current (peak value)	Time
H3CR-F		24 VAC/DC	26.4 VAC	0.7 A	10 ms
			26.4 VDC	1.1 A	9.4 ms
		12 VDC	13.2 VDC	52 mA	3.3 ms
		48 to 125 VDC	137.5 VDC	0.40 A	9.1 ms
H3CR-H	S-series	100/110/120 VAC	132 VAC	1.05 A	111 ms
		200/220/240 VAC	264 VAC	1.07 A	119 ms
		24 VAC/DC	26.4 VAC	1.26 A	133 ms
			26.4 VDC	0.85 A	137 ms
		48 VDC	52.8 VDC	0.73 A	112 ms
		100 to 125 VDC	137.5 VDC	0.62 A	109 ms
	M-series	100/110/120 VAC	132 VAC	1.02 A	364 ms
		200/220/240 VAC	264 VAC	1.03 A	323 ms
		24 VAC/DC	26.4 VAC	1.21 A	478 ms
			26.4 VDC	0.87 A	560 ms
		48 VDC	52.8 VDC	0.71 A	384 ms
		100 to 125 VDC	137.5 VDC	0.62 A	380 ms

- Note:**
1. The above figures are all approximations and should be used for reference only.
 2. The inrush current is given mainly for DC models for the required power supply design specifications. For the H3CR-H, the inrush current is also given for 100/110/120-VAC and 200/220/240-VAC models because these models have higher inrush currents than other series.

Input/Output (H3CR-H)

An appropriate input is applied to the input signal terminal of the Timer when the input terminal for the input signal is short-circuited. Do not attempt to connect any input terminal to any terminal other than the input terminal or to apply voltage across other than the specified input terminals or the internal circuits of the Timer may be damaged.

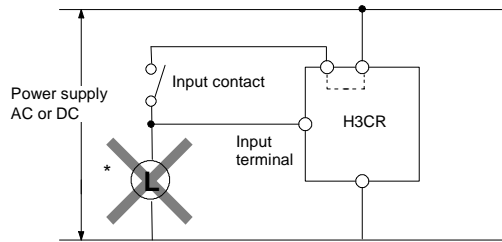

*Do not connect a relay or any other load between these two points, otherwise the internal circuit of the Timer may be damaged due to the high-tension voltage applied to the input terminals.

When connecting a relay or a transistor as an external signal input device, pay attention to the following points to prevent short-circuiting due to a sneak current to the transformerless power supply. If a relay or transistor is connected to two or more Timers, the input terminals of those Timers must be wired properly so that they will not be different in phase or the terminals will be short-circuited to one another (refer to the figures below).

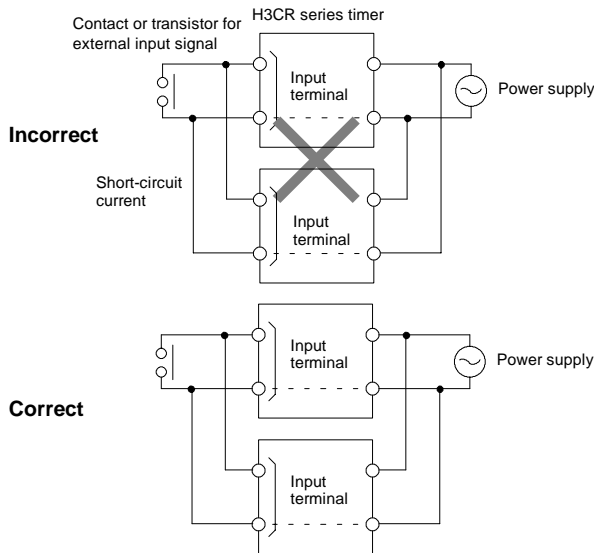

Environment

When using the Timer in an area with excess electronic noise, separate the Timer, wiring, and the equipment which generates the input signals as far as possible from the noise sources. It is also recommended to shield the input signal wiring to prevent electronic interference.

Organic solvents (such as paint thinner), as well as very acidic or basic solutions can damage the outer casing of the Timer.

Others

If the Timer is mounted on a control board, dismount the timer from the control board or short-circuit the circuitry of the power board before carrying out a voltage withstand test between the electric circuitry and non current-carrying metal part of the Timer, in order to prevent the internal circuitry of the Timer from damage.

ALL DIMENSIONS SHOWN ARE IN MILLIMETERS.

To convert millimeters into inches, multiply by 0.03937. To convert grams into ounces, multiply by 0.03527.

Cat. No. L86-E1-2B **In the interest of product improvement, specifications are subject to change without notice.**

OMRON Corporation

Systems Components Division
28th Fl., Crystal Tower Bldg.
1-2-27, Shiromi, Chuo-ku,
Osaka 540 Japan
Phone: 06-949-6012 Fax: 06-949-6021

Printed in Japan
0697-0.5M (0696) a